

Manual

Stack Cutter



 **LOGOSOL**

Thank you for choosing a LOGOSOL product

For use with chainsaws, LOGOSOL has been making mini-sawmills since 1988. *Logosol Sawmill*, our most famous product, is the world's best selling sawmill in all categories.

LOGOSOL has a wide range of products for small-scale wood processing. Covering everything from felling to finished product, this range enables you, the user, to take care of everything yourself.

LOGOSOL also manufactures cutting equipment for large sawmills. *Top Splitter* is an auxiliary cutter that sits above the main saw. *Big Mill* cuts outside logs so that they can be taken into the sawmill.

Specialised planers such as the PH 260, which can shape all four sides of a board in a single pass, are also in our product range. For information about the entire range, simply ring LOGOSOL. If you are interested in a particular product, then we have videos that show our machines in action.

You are now the proud possessor of *Stack Cutter*, a low-maintenance, high-efficiency machine that does exactly what its name says. If you have any questions or suggestions about *Stack Cutter*, please do not hesitate to call LOGOSOL. Our goal is that you too will become yet another satisfied owner of a LOGOSOL product.

Happy stack cutting!



Bengt-Olov Byström
MD and designer

Contents

| | |
|-------------------------------------|----|
| Machine description | 2 |
| Safety instructions | 3 |
| Safety instructions | 4 |
| Moving the cutter | 7 |
| Setting up the cutter | 7 |
| Preparing stacks for cutting | 8 |
| Cut positioning | 9 |
| Setting cut length | 10 |
| Electrical connection | 11 |
| The control panel | 11 |
| Stack cutting | 12 |
| Changing cutting equipment | 13 |
| Maintenance – cutting equipment | 14 |
| Sharpening the chain | 14 |
| Troubleshooting – cutting equipment | 15 |
| Maintenance – <i>Stack Cutter</i> | 16 |
| Assembly/Spare parts | 17 |
| Adjustments | 27 |
| Circuit diagram | 28 |
| Technical data | 29 |
| EU declaration of conformity | 29 |

Machine description

Stack Cutter is a machine designed for making vertical cuts in timber stacks.

Stack Cutter cuts with great precision. A measuring stick is used to determine cut position and the machine is then secured to the stack. The guide bar is ball bearing controlled at its tip. The chain is a 3/8" crosscut chain driven by a 5 kW 3-phase electric motor.

Guide bar length, machine height, fitments, etc are all adjustable. There are two standard *Stack Cutter* models, one has a 120 cm guide bar and the other a 150 cm guide bar.

The machine is based on a sturdy stand with an electric saw suspended from a robust line.

With the guide bar in its top position, the saw chain is covered by a fixed guard. During operation, an adjustable guard at the tip off the guide bar provides further protection.



Printed using vegetable-oil based inks on chlorine-free, recyclable paper.

As development at LOGOSOL is continuous, we reserve the right to make changes in the design and/or construction of our products without warning.

Text: Mattias Byström

Illustrations: Mattias Byström 26 Nov 2002

Copyright 2002 LOGOSOL, Härnösand, Sweden

Safety instructions

! In addition to the instructions given here on pages 4 and 5, further warnings and reminders are given throughout the manual.



For your own safety, read this manual thoroughly and do not start the machine if you have not understood everything in it. Do not let anyone who has not read and understood the manual use the machine.



Wear safety gloves when using *Stack Cutter*. Risk of cuts and burns!



Wear approved ear protectors. Hearing can be damaged even on short exposure to high-frequency sounds. Wear approved safety glasses. The machine can throw out chips and other wood debris.



Stack Cutter is a cutting machine! When it is in use, never stick hands or tools beyond the protective glass screen or the control panel.



This symbol stands for **WARNING!** Take extreme care whenever this symbol is used in the text.



This symbol stands for **CAUTION!** Take extra care whenever this symbol is used in the text.

! If used incorrectly, *Stack Cutter* can cause serious personal injuries. Always pay great attention and work methodically when using the machine.

! Only people who have read and understood everything in this manual, are in good physical health and have good eyesight are authorised to use *Stack Cutter*. No other persons may use *Stack Cutter*.

! Be aware that accidents with dangerous wood processing machines most often occur when the operator is, for example, attempting to remove shavings/chips that have jammed, or is trying to correct minor problems. Stop *Stack Cutter* immediately there is any operating problem. Stops do not generally show in the finished article.

Workplace

! For the greatest electrical safety, ensure an **earth-leak circuit breaker** is fitted.

- When using *Stack Cutter*, always have a fire extinguisher within easy reach.
- Keep the workplace tidy. Do not leave anything you can trip over lying on the ground.
- The workplace should be well illuminated, but there must not be any risk of dazzling.
- The machine must not be used or stored in temperatures below zero degrees centigrade.
- Do not tread on the machine's power cable. The cable should be secured off the ground.
- Do not climb onto the machine.
- Never walk under, or stride over, the machine's guide bar.
- Never stand in a position where you can be hit by the motor bracket. There is a **risk** that the guide bar and motor bracket will drop if the winch safety catch is accidentally taken off or if the lifting line breaks.

! Before starting *Stack Cutter*

- Check that the saw chain, all control handles, bolts, nuts, stops, guards, etc are properly attached/tightened.
- Check that the saw chain can rotate freely and that no tools or loose parts have been left in the machine.
- Check that all guards are correctly positioned and that they cover the saw chain properly.
- Check that *Stack Cutter* has been properly set up, is stable and has all its wheels locked.
- Check that the saw unit's winch and lifting line are undamaged.
- Check that the guide bar is in its top position and held securely in place by the winch.

ⓘ During operation

Do not start stack cutting before all the operations described in "Preparing stacks for cutting" (page 8) have been carried out.

Never start the cutter if the guide bar is not in its top position and completely covered by the fixed bar guard.

Never stick hands or tools under any guards or in the guide bar's cutting path.

Always stand so that your face is protected by the safety screen. When end trimming, the chain can throw blocks of wood in the operator's direction.

On the same axis as the guide bar, with a 20 degree deviation to either side, the safe distance "in front of" and "behind" the machine is 8 m (see the diagram). This also applies to the operator. Besides the operator (shown as "Op" in the diagram), no one may stand within 4 metres of the machine's sides while it is operating. The diagram below shows a bird's-eye view of the machine. During operation, the operator must stay within the indicated area behind the control panel. The operator must not stretch his/her arms or legs outside this area.

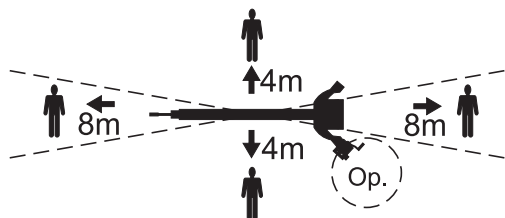

⚠ Risk of the saw chain flying out if it breaks! Respect the safe distance!

Do not wear loose fitting clothes or anything else that can catch in the machine's moving parts.

Never use the machine when visibility is poor. Always work in good lighting.

Do not use the machine under the influence of alcohol or other drugs.

ⓘ Miscellaneous:

The machine must not be modified or added to. Use only parts supplied by LOGOSOL. After servicing, the machine must be returned to its original condition.

⚠ Risk of being hit by the winding crank!

⚠ Risk of the saw unit being lowered unintentionally!

- ⓘ Before releasing the winch safety catch, take a firm grip of the winding crank. Except when the saw unit is to be lowered, the safety catch should always be on.

⚠ Risk of burns when changing the chain! Cutting equipment can be hot after use!

- ⓘ A chip fan (min. 700 m³/h) must be connected during operation. Be aware of the risk of breathing in dust. Saw outdoors or ensure good ventilation.
- ⓘ Even people outside the safe distance may still require ear protectors. Outdoors, the safe distance for harmful noise is around 15 m. Ensure that no one without ear protectors is exposed to sounds above 70 dB(A).

- ⓘ Use non-toxic, vegetable, saw chain oil to lubricate the chain.

⚠ Risk of unintentional start-up and electric shock!

- ⓘ In this manual, the instruction "disconnect the power" **always** means unplug the power cable at the control panel, hang it up so that neither the plug nor the cable can be damaged and ensure that the chain has stopped.

ⓘ Disconnect the power

- Before touching the chain in any way.
- Before attempting to free a jammed chain.
- Before servicing or other intervention involving the guide bar, belt guard or electrical system.
- Before moving the machine.
- If the machine is to be left unsupervised. Ensure also that no unauthorised person can start the machine.
- After fitting a chain, ensure that it runs freely before plugging the cable into the control panel.

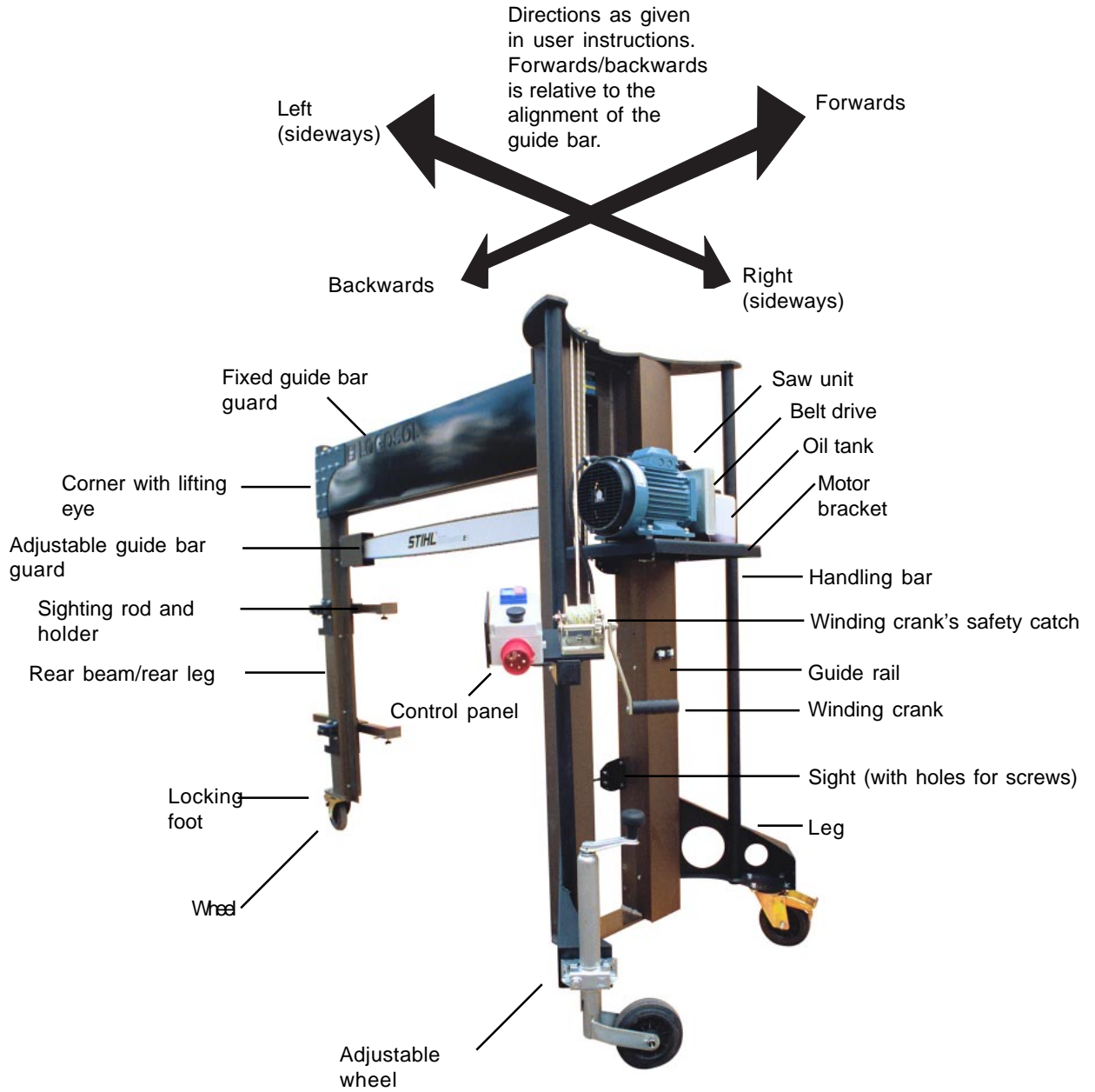

Moving the cutter

Thanks to its wheels, *Stack Cutter* can be easily moved when required. Whenever possible, *Stack Cutter* should be moved in the longitudinal direction of the guide bar (i.e. not sideways). The high centre of gravity makes the machine unstable if it is moved sideways.

If *Stack Cutter* is being moved more than a short distance, the motor unit must be lowered to its bottom position. The risk of toppling increases considerably if *Stack Cutter* is moved sideways (right/left). The floor over which *Stack Cutter* is moved must be smooth and free from gravel and anything else that can make it uneven.

- ❗ Disconnect the power before moving *Stack Cutter*.
- ⚠ Risk of toppling! *Stack Cutter* may only be moved on its wheels when the surface is smooth and even.
- ⚠ Risk of toppling! The maximum permitted speed when moving sideways is 0.2 m/sec. (1 m in 5 sec.).
- ❗ During moving, pay particular attention to ensuring that the control panel does not hit any obstacles.
- ❗ During moving, the winding crank's safety catch must always be on.

Stack Cutter can be easily moved using a crane, tractor or other equipment suitable for this purpose. Use approved lifting straps/lifting chains. *Stack Cutter* has a lifting eye at the top of the rear beam. On the motor-side, thread the straps or chains between the handling bars and the rule. Ensure that the guide rail is properly secured by the straps/chains. When lifting, ensure that no one stands under, or in the immediate vicinity of, the load. Match the speed of travel to the prevailing conditions.



End trimming with Logosol's Stack Cutter

- ❗ Note where the operator is standing, the position of his hands, that the guide bar top guard is offset towards the stack, that the stack stands firmly on flat ground and that it is properly strapped.

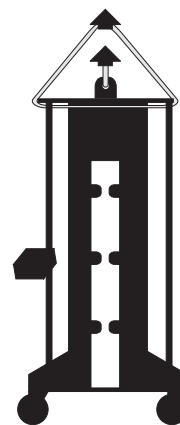
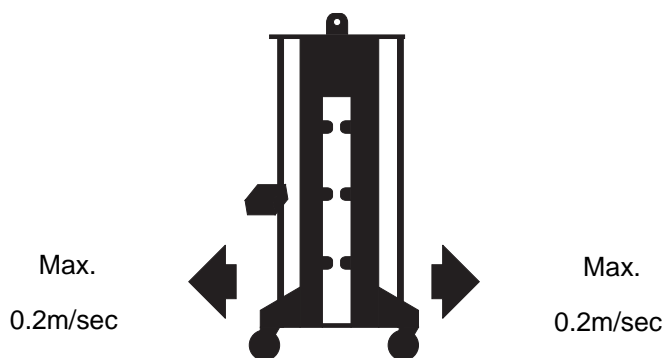

Setting up the cutter

- ❗ Read the entire manual and, before using the machine, familiarise yourself with all the machine's functions and settings.
- ❗ Inspect *Stack Cutter* immediately on reception. Any transport damage must be notified immediately to the freight company.

Position *Stack Cutter* on an even surface. Using the crank on the adjustable wheel, adjust the machine so that it is level and stable.

Using hose clips at both the machine end and the fan end, connect the hose for the chip fan.

Ensure that the lighting is first-class. Fit a powerful light above the machine.

Check that all bolts are correctly tightened.

Check that the saw chain runs freely and unobstructed on the guide bar. Check that the chain has been tensioned (see page 13).

Preparing stacks for cutting

- ❗ Ensure that there is no electrical power to the machine while the stack is being prepared.
- ❗ End trimming (F) refers to cutting the end off a stack. The longest waste piece sawn off must be min. 10 mm and max. 500 mm.

⚠ Risk of chain breakage!

- ❗ **If the stack's set-up and the positioning of crossers and straps is not correct, *Stack Cutter* will not be able to cut correctly.** The guide bar will either jam or the chain will lift out of its groove. There is a great risk of chain breakage when this happens.

⚠ Risk of the stack toppling!

- ❗ Ensure that the part of the stack that is to be cut off will still stand firmly supported after the cut is made (A).

Stack Cutter is supplied with a measuring stick that has a scale and an adjustable stop plate. To prepare a

stack for cutting, first mark out the approximate position of all the cuts. Do not forget to take the cut's width into account.

Exact measurements are made between each saw cut (see "Setting cut length").

The ground where the stack is set up should be flat and even. Plan the sequence in which the cuts (B) will be made. With the exception of end trimming (where support is required on one side only), there must be stable supports (C) on the ground on each side of the cut. Supports must be at least 150 mm high.

With the exception of end trimming (where strapping is required on one side only), the stack must be firmly strapped (D) on both sides of the cut.

- ❗ Viewed from the cut, any strapping (E) must lie on the far side of any crossers.
- ❗ There must not be any strapping between crossers and the cut.

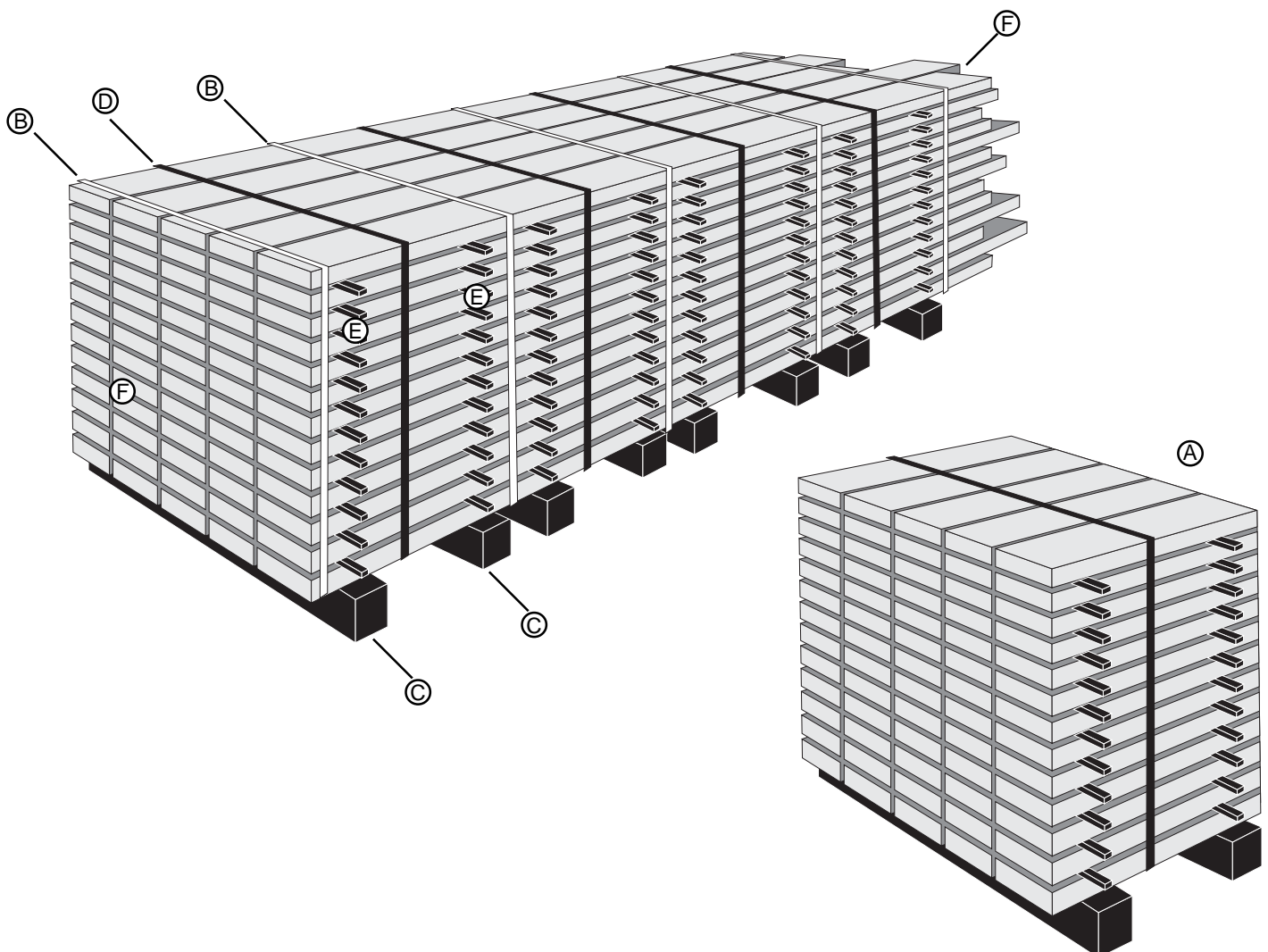

Control panel

⚠ Do not connect the machine to a power supply before you have read and understood the entire manual. Incorrect use may result in a fatal accident.

- A Green button: Start
- B Raised red button: Emergency stop/stop
- C Round black button: Safety button (dead man's handle)
- D Motor unit winding crank
- E Plug socket
- F Phase inverter
- G Winding crank safety catch

Start:

Hold down the safety button and, at the same time, press the green start button.

Stop:

Press the red stop button.

Emergency stop:

Press the red stop button or release the safety button.

⚠ Risk of being hit by the winding crank!

⚠ Risk of the saw unit being lowered unintentionally!

⚠ Before releasing the safety catch (G), take a firm grip of the winding crank (D). Except when the saw unit is to be lowered, the safety catch should always be on.

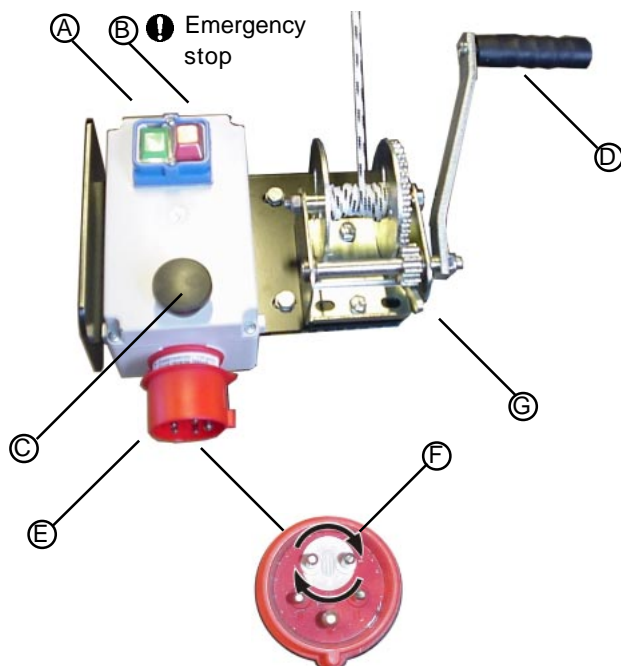

Electrical connection

⚠ Risk of electric shock.

⚠ Do not connect the machine to a power supply before you have read and understood the entire manual. Incorrect use may result in a fatal accident.

⚠ *Stack Cutter* should be connected via an earth-leak circuit breaker.

Fix the machine's power cable to the ceiling or protect it in some other way. Never tread on the cable.

Position the machine so that the green start button and red stop button are immediately accessible.

The red stop button functions as an emergency stop button and must not be disabled in any way.

The round black button is a so-called "dead man's handle" that must be physically held down by the operator during operation.

When all the instructions under "Setting up the cutter" have been followed:

With the guide bar in its top position, plug the machine in (E) and check that the motor is running in the right direction. Look at the chain in the guard from a safe distance – see safe distance in the safety instructions. On the underside of the guide bar, the chain should be running in towards the saw unit. If it is not, pull the plug out of the machine and switch the phases in the plug by using a large flat screwdriver to turn the disc (F) that holds two of the pins.

⚠ Risk of electric shock!

⚠ Only qualified electricians are authorised to open/access the electrical system.

⚠ The plug does not need to be opened to switch the phases.

Stack cutting

⚠ Risk of serious injury if the warnings and instructions in this manual are ignored!

! Before cutting begins...

...you must have read and understood the warnings and other instructions in this manual.

...*Stack Cutter* must have been correctly set up in the right position as per the sections "Preparing stacks for cutting" and "Cut positioning".

Lower the guide bar towards the stack. Select a suitable length guard (A) for the guide bar's tip and set the guard to come as near as possible to the stack. Winch the guide bar back up to its top position.

! The maximum permitted distance between the stack and the guide bar guard is 50 mm. Long guide bar guards can be ordered from Logosol.

! So that you do not saw through anything unintentionally, check the guide bar's path and the ground beneath the guide bar.

! Before cutting, check that the saw chain runs freely and unobstructed on the electric saw. Wear safety gloves.

! Do not plug the power cable into the machine until it is fixed in the right position.

⚠ Risk of the operator being hit by wood debris thrown backwards in the chain's direction!

! Always stand with your face shielded by the protective screen. Wear safety glasses.

! Refer to the section "The control panel". Take a firm grip of the winding crank when taking off the safety catch.

! During cutting, the saw unit must not be pushed downwards to increase feed pressure. The saw unit's maximum feed pressure must be its own weight. Take great care if the saw chain jams because of "pinching". If, at any time, the saw unit does not descend easily through the stack, stop cutting immediately. Disconnect the power and remedy the fault. The cause may be that the saw chain has jammed due to inwards pressure from both sides ("pinching") and, as a result, has lifted from its groove on the top of the guide bar.

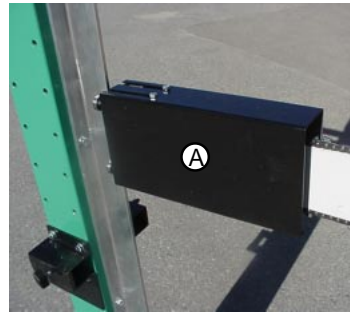

⚠ **Extreme risk of chain breakage if the chain lifts out of the guide bar's groove! Risk of fatal accident!** If the chain breaks, it may fly out at high speed, either forwards or backwards, along the axis of the guide bar.

Wind the saw slowly down to the stack and continue all the way through the stack. Wind extra slowly when trimming to avoid bar bending.

Stop the cutter by releasing the safety button or by pushing the red stop button (see the section on the control panel).

Drawing the line for end trimming

The basic procedure when using *Stack Cutter* is to mark out the intended cut by drawing lines on the stack's sides.

Draw a vertical line on both sides of the end of the stack that is to be trimmed. Waste pieces must not be shorter than 10 mm or longer than 500 mm.

Cut positioning

1. Position the cutter by the drawn line.
2. Using the wheel crank, adjust *Stack Cutter* to approximately the correct angle.



3. Align the upper sight exactly with the line. On the side that is not going to be cut off, fix a screw into the stack through the hole in the sight.
4. Use the wheel crank to fine adjust the lower sight.



5. Go around the machine and align with the cut on the opposite side.

The sighting rod must be on the side of the stack that is not going to be taken away.

The sighting rod's holder must be fitted in such a way that you can measure close to the centre of the stack.

6. Push the sighting rod close to the stack.
7. Ensure that the plastic sight pegs are close to the horizontal position.
8. Tighten the sighting rod in its holder.



9. Align *Stack Cutter* and lock the position by pushing down the locking foot next to the wheel (and, if desired, screwing the sighting rod into the stack – in which case, disregard point 10).
10. Loosen the sighting rod, pull it back and, so that the plastic pegs do not get in the way of the saw chain, turn it 90 degrees.

⚠ Risk of sawn off pieces of wood flying in the operator's direction!

! Stand behind the protective screen. Wear safety glasses. Ensure all other people observe the safe distance.

13. Cut along the line as per the instructions in "Stack cutting". Observe all the warnings.

When making the first cut, calibrate the machine's plastic sight pegs by pushing them out a few millimetres and then sawing them off. This will show the exact path of the guide bar.

Setting cut length



End trimming



At the top and the bottom of both sides of the stack, set the stop plate against the cut surface and mark the end of the rod.

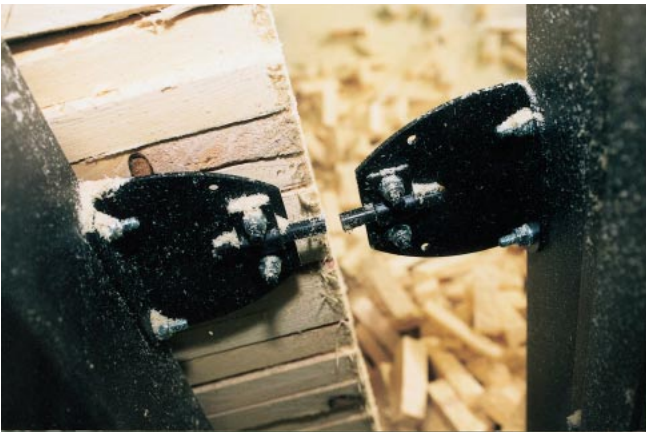

Once one of the stack's ends has been trimmed, the cut surface provides the point for measuring the position of the next cut.

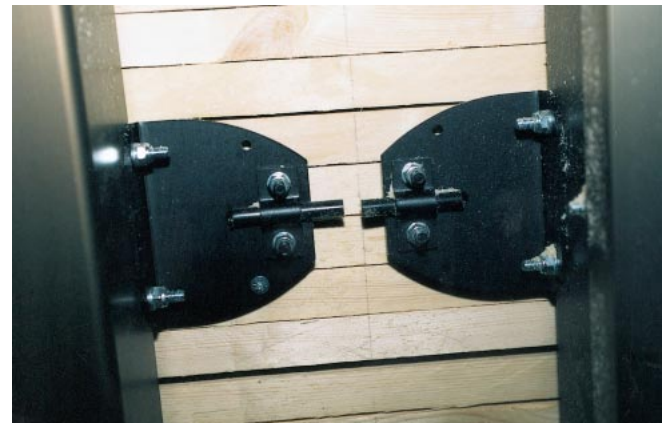

On both sides of the stack, draw a line between the marks. The top of the stack need not be marked.



Set the measuring stick's stop plate to the desired length.

Using the sights and the sighting rod, align the cutter so that the saw chain will cut along the lines in the same way as described in the end trimming section on the previous page.

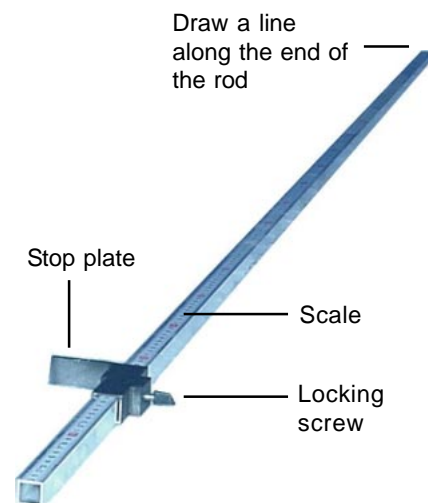

Using the measuring stick, measure out and draw the lines for the next cut. Position *Stack Cutter* and repeat the cutting procedure.

Changing cutting equipment

After a while, the saw chain will lose its edge.

The saw chain can be easily removed for sharpening. An electric grinder is recommended for sharpening, but it is also possible to use a round saw chain file.

To guarantee that the correct equipment is used, saw chains, chain sprockets and guide bars should be purchased from Logosol.

A new chain may need re-tensioning after the first or second cut.

Risk of cuts and burns!

 Before commencing servicing, ensure that the power is disconnected and that the saw chain is not rotating. The chain may be hot. Always wear safety gloves.

Removing the guide bar and chain

When changing the chain, it is not necessary to remove the guide bar tip control.

1. Remove the flexible chip duct.
2. Lay the chain around the guide bar and tape it fast so that it does not hang below the bar.
3. Place a support, e.g. a euro pallet, beneath the guide bar.
4. Lower the motor unit until the guide bar is resting on the support.
5. Set the chain tensioner (C) to its rearmost position.
6. Undo the guide bar nuts (A) and the cover plate (B) that the oil pump sits on.
7. Lift the guide bar out.

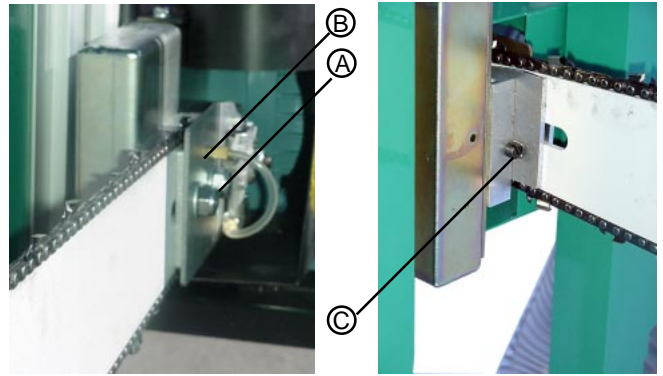

Fitting

The “shortness” of a new chain may make fitting it around the sprocket difficult. Chains stretch with use and are then easier to fit.

(Remove the flexible chip duct.)

1. Lay the chain around the guide bar and tape it fast so that it does not hang below the bar.
2. During fitting, lower the motor unit until it rests on a support, e.g. a euro pallet.
3. Check that the chain tensioner (C) is in its rearmost position.
4. Rest the guide bar on the support.
5. Fit the guide bar tip control to the T-profile (depending on chain length, this can sometimes not be done before the chain is tensioned).
6. Fit the guide bar to the guide bar bolts (A). Pull the saw chain around the chain sprocket. Check that the sprocket sits tight to the bearing housing and that the collars of the guide bar bolts are in the guide bar's groove.
7. Push the cover plate (B) down over the bolts and tighten (hand-tight) the nuts.
8. Check that the guide bar, chain and tip control are correctly positioned.
9. Using the chain tensioner (C), tighten the chain. The chain must be tensioned to the point where it sits against the underside of the guide bar.
10. Tighten the guide bar nuts (A).
11. Wearing safety gloves, rotate the chain by hand and check that it runs correctly around the guide bar. If it does not, the chain may not be correctly threaded around the sprocket or it may be over-tensioned.
12. Checking that the guide bar tip control is in the correct position all the way, raise the saw unit to its top position.
13. Refit the flexible chip duct.

Maintenance – cutting equipment

If you keep your cutting equipment in good condition, the sawn product will have the right dimensions, cutting will be speedy and the equipment will last longer.

When the timber you are cutting is “aggressive” to the chain (e.g. dry wood, hard wood, or timber that has sand or earth in the bark), regular sharpening of the chain is particularly important.

File before cutting slows down

When the chain starts to lose its edge, the cutting speed falls, the guide bar gets hot and descends through the stack more slowly. Stop cutting immediately! Really, filing has already been delayed too long. Cutting with a dull chain subjects the cutting equipment to great stresses. Thus, always file before the chain becomes dull!

File comfortably

Filing by hand or using an electric chain grinder both give good results. The chain does not need to be removed for manual filing. We recommend a double file that has an integral depth gauge file (Pferd 5.5 mm, art. No. 9999-000-0420).

❗ Filing angle – 10 degrees! Keep the file flat over the cutters.

Avoid chain breaks

Cutting too long with a dull chain can result in breakage. The chain will break under the cutters (inspection will show excessive wear at this point).

If, however, a drive link breaks, this may be because the chain and the sprocket are not well matched. Check the sprocket every time you change the chain.

❗ Change the chain sprocket when the sprocket's

teeth show small indentations. These are a sign of wear.

Sharpening the chain – keep the edge in the chromium layer!

The cutters on the chain of a motor saw are coated with a very thin layer of chromium. This gives a very sharp and wear-resistant edge.

As long as the edge is in the chromium layer, the chain is perfectly sharp.

If you always file before the chain becomes dull, the guide bar and the chain will be subject to minimal wear.

If, on the other hand, you make 5 – 10 cuts after the edge has left the chromium layer, the chain becomes dull and cutting is poor. Saw speed is low and feed pressure is high. The bar and the chain rapidly overheat. It is still possible to cut under these conditions, but the equipment wears very quickly.

When filing a dull chain, there is a clear risk of not reaching the chromium layer. The chain will be sharp but, as the edge is not in the chromium layer, it will soon become dull again.

If you do not file in time, you will have to file away a large part of each cutter to make it sharp. This considerably reduces the chain's service life. If a lot of cutting is done with a dull chain, the feed pressure will be high. Consequently, the bar will wear quickly and there is a risk of chain breakage.

Summary – File before the chain becomes dull. This prevents the setting up of a vicious circle in which wear is high and cutting results poor.

Troubleshooting – cutting equipment

The guide bar must not cut at an angle. Any fault in this respect is most clearly noticeable when the guide bar is raised after a cut has been made. If the bar does not gently rest against the cut surface, but pushes against it, or hangs away from it, there may be a fault with the bar or the chain.

Causes of faults in the cutting equipment

1. A dull chain is one cause of a problem when using *Stack Cutter*.
2. The chain may have been damaged on one side, e.g. by a metal object in the wood. The chain will still cut, but will pull to one side.
3. The chain has been filed incorrectly. The cutters on one side have been filed down less than those on the other. To achieve a more even result, try to have the same working position when filing the right and left sides of the chain. That a few teeth are damaged or completely lost after cutting through a nail does not normally have a noticeable effect on the chain's performance.
4. When precision decreases after a period of problem-free cutting, guide bar wear is almost always the cause.

The guide bar may pull to one side

If the chain has been damaged on one side, or filed unevenly, it can run incorrectly. It will then increase the wear on one side of the guide bar and, if cutting is continued, wear the bar at an angle. Even if the chain is changed, a bar that has been worn at an angle will guide incorrectly and may even wear the chain at an angle.

A guide bar that has been worn at an angle can be repaired. Using, for example, a UKF file (art. no. 9999-000-0450), file the guide bar rails to an even height.

Another common cause of the guide bar pulling to one side is wear that has resulted in the drive links bottoming in the groove. This deprives the chain of its support from the guide bar rails. The chain shows this through the tips of the drive links being worn.

Test the chain oil with your fingers

Always use vegetable chain saw oil.

For the chain oil to work well, it must be viscous and form threads. When a drop is squeezed between thumb and index finger, many threads should form when these digits are re-opened. If only 2 – 3 threads form, the oil's adhesion is insufficient and the oil will fly off the tip of the guide bar. We recommend Stihl chain oil (5 litres, art. no. 0781-516-3353).

The oil flow is set by a screw on the oil pump. Flow is set to maximum at the factory and must not be altered.

Maintenance

Stack Cutter is easy to maintain. As 95% of the structure is protected against rust, it can stand in the cold. However, extra maintenance is then required – parts that are not rust protected must be lubricated.

Necessary maintenance is set out below.

⚠ Before commencing servicing or removing any guard, ensure that the machine's power supply has been disconnected.

Check that the chain is well lubricated. Check the oil level and, if topping up, use a suitable chain oil (e.g. ISO VG 68). Safety gloves must be worn for all handling of oil.

⚠ Risk of the lifting line breaking and the motor unit falling!

⚠ Before every work session, check that the saw unit's lifting line is in good condition. If there is any sign of damage or wear, the line must be replaced immediately. When replacing, ensure that both ends of the new line are securely attached.

After every work session, the entire machine must be cleaned of wood debris. Check that electrical cables, connections and contacts are in good condition.

If the machine is not going to be used for some time, the power should be disconnected (see "Safety instructions"). Also ensure that no unauthorised person can connect the machine. Thoroughly clean the machine. Using a suitable brush or rag, lubricate all the machine's moving parts (wheels included) with oil. To prevent any build-up of condensation in the machine's electrical components, the machine should be stored in heated premises that are kept at an even temperature (not below zero degrees centigrade).

Changing the drive belt

The drive belt between the motor and the guide bar fastening must be regularly changed. Always keep a spare drive belt handy.

⚠ Before removing the belt guard, ensure that the power to the machine has been disconnected.

1. Place a support, e.g. a euro pallet, beneath the guide bar.
2. Lower the motor unit until the guide bar rests on the support. Slacken off (a few turns) the four bolts holding the belt guard.
3. Lift the guard away.
4. Slacken the belt by slightly loosening the guide bar fastening and then removing the bolt (A) that presses against this fastener.
5. Replace and tension the belt.
6. When the belt is correctly tensioned, a force of 10 kg halfway between the pulleys gives 5 mm of "spring".
7. While tensioning the belt, check that the guide bar tip control sits correctly in the T-profile. Check that the belt is correctly seated on the pulleys. Tighten the bolts for the fastening.
8. Refit the belt guard. Check that all bolts are properly tightened.

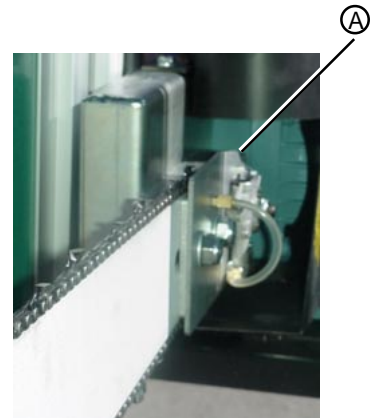

Assembly

The degree of pre-assembly depends on the type of packing that is most suitable for your particular delivery.

Labels are used to facilitate the assembly of some of the machine's parts. For example, fit label A to label A.

Stack Cutter should otherwise be assembled in the order given in pages 16 – 19. For positions given with a number only, refer to these pages.

Note the following:

- ❗ The joint at positions 12-13 and 15-16 should not be fully tightened before *Stack Cutter* is fully assembled and adjusted (see page 25).
- ❗ Positions 20 to 22 should not be fully tightened before the top plate (56) is fitted.
- ❗ If the motor unit (53 and page 22) is delivered fitted to the motor bracket (52), it must be removed and only refitted when the motor bracket is in place and the line (70) is correctly fitted between the winch (66) and the bracket.

Estimated assembly time – It takes approximately half a day to unpack the machine and have it ready for use. A battery-powered screwdriver with 10 mm and 13 mm sockets will facilitate assembly.

Tools required

Which tools are required depends on the machine's degree of pre-assembly. The tools listed below are for a machine with no pre-assembly. Tools are not included in delivery.

| | | |
|------------------|-------|---|
| Hexagon spanner | 8 mm | 1 |
| Hexagon spanners | 10 mm | 2 |
| Hexagon spanners | 13 mm | 2 |
| Hexagon spanners | 17 mm | 2 |
| Hexagon spanner | 19 mm | 1 |

A battery-powered screwdriver with 10 mm and 13 mm sockets will facilitate assembly.

Accessories and spare parts

Guide bars, chains, sprockets and other spare parts can be ordered from LOGOSOL. See the article lists on the following pages.

Order LOGOSOL's product catalogue.

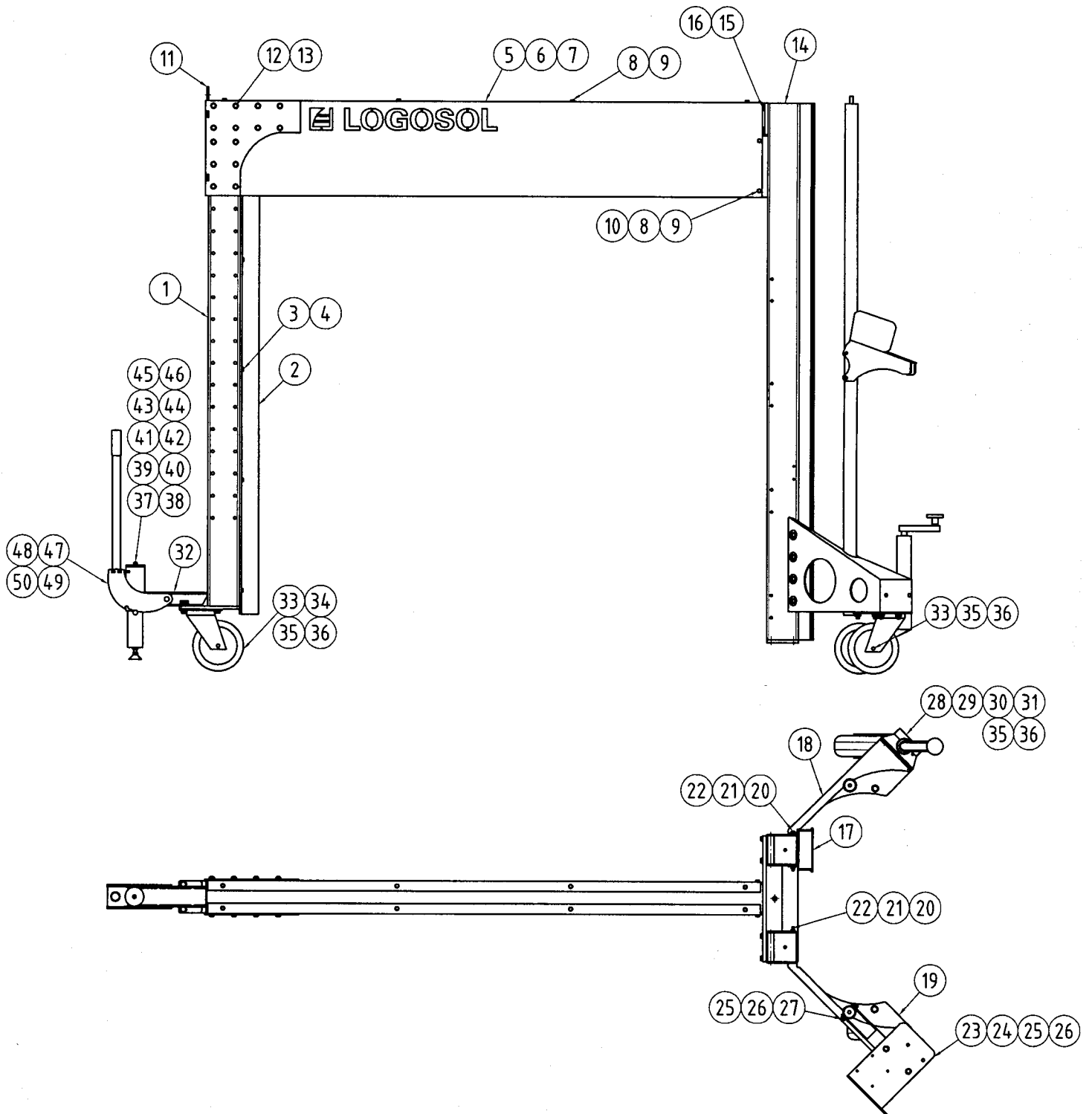

| Part no. | Number | Designation | Information | Article number |
|----------|--------|--|--------------------|----------------|
| 1 | 1 | Rear leg | Pk-13 | |
| 2 | 1 | Rear leg corner profile | Pk13-2 | |
| 3 | 10 | Hexagonal bolt | M6S 933 M6x20 | 0000-200-0001 |
| 4 | 10 | Round washer | Brb 125A 6.4 Fzb | 0000-800-0003 |
| 5 | 1 | Beam | Pk-15 | |
| 6 | 1 | Left guard | Pk-18 | |
| 7 | 1 | Right guard | Pk-18-1 | |
| 8 | 12 | Hexagonal bolt | M6S 933 M6x20 | 0000-200-0001 |
| 9 | 12 | Round washer | Brb 125A 6.4 Fzb | 0000-800-0003 |
| 10 | 4 | Locking nut | 985 M6 Fzb | 0000-500-0001 |
| 11 | 1 | Corner | Pk-14 | |
| 12 | 14 | Hexagonal bolt | M6S 931 M8x120 FZB | 0000-200-0030 |
| 13 | 1 | Hexagonal nut | M6M 934 M8 Fzb | 0000-500-0006 |
| 14 | 1 | Front leg | Pk-17 | |
| 15 | 8 | Hexagonal bolt | M6S 931 M8x35 FZB | 0000-200-0032 |
| 16 | 8 | Round washer | Brb 125A 8.4 Fzb | 0000-800-0002 |
| 17 | 1 | Rule, stack-cut | Pk-16 | |
| 18 | 1 | Right leg | Pk-11, pos 1 | |
| 19 | 1 | Left leg | Pk-11, pos 2 | |
| 20 | 11 | Hexagonal bolt | M6S 931 M6x120 FZB | 0000-200-0029 |
| 21 | 11 | Round washer | Brb 125A 6.4 Fzb | 0000-800-0003 |
| 22 | 11 | Locking nut | 985 M6 Fzb | 0000-500-0001 |
| 23 | 1 | Fitment holder | | |
| 24 | 2 | Hexagonal bolt | M6S 933 M8x20 Fzb | 0000-200-0011 |
| 25 | 4 | Round washer | Brb 125A 8.4 Fzb | 0000-800-0002 |
| 26 | 4 | Hexagonal nut | M6M 934 M8 Fzb | 0000-500-0006 |
| 27 | 2 | Hexagonal bolt | M6S 931 M8x60 Fzb | 0000-200-0037 |
| 28 | 1 | Support 1025 incl. fastener excl. wheel | 12201 | |
| 29 | 1 | Rubber wheel with needle bearings 160 mm | | T32422 |
| 30 | 1 | Tubular sleeve | 20x1.5x84 | 11810 |
| 31 | 1 | Hexagonal bolt | M6S 933 M10x25 FZB | 0000-200-0019 |
| 32 | 1 | Fastener, pressure foot | Pk-pf-05-2 | |
| 33 | 2 | Rubber castor, 160 mm BR | 31335 | 11220 |
| 34 | 4 | Hexagonal bolt | M6S 933 M10x30 FZB | 0000-200-0027 |
| 35 | 14 | Round washer | Brb 10.5x22x2 Fzb | 0000-800-0008 |
| 36 | 8 | Locking nut | 985 M10 Fzb | 0000-500-0007 |
| 37 | 1 | Pressure sleeve, pressure foot | Pk-pf-15 | |
| 38 | 1 | Shaft | Pk-pf- | |
| 39 | 2 | Insert nut | M8 | |
| 40 | 1 | Spring | | |
| 41 | 1 | Small washer | Pk-pf- | |
| 42 | 1 | Large washer | Pk-pf- | |
| 43 | 1 | Triangle | | |
| 44 | 1 | Locking nut | 985 M6 Fzb | 0000-500-0001 |
| 45 | 1 | Adjustable foot | SF 20 41 | |
| 46 | 1 | Nut | M6M 934 M10 Fzb | 0000-500-0008 |
| 47 | 1 | Tensioning arm, pressure foot | Pk-pf-05-2 | |
| 48 | 1 | Lever | | |
| 49 | 1 | Insert bolt | M8x | |
| 50 | 1 | Insert nut | M8 | |

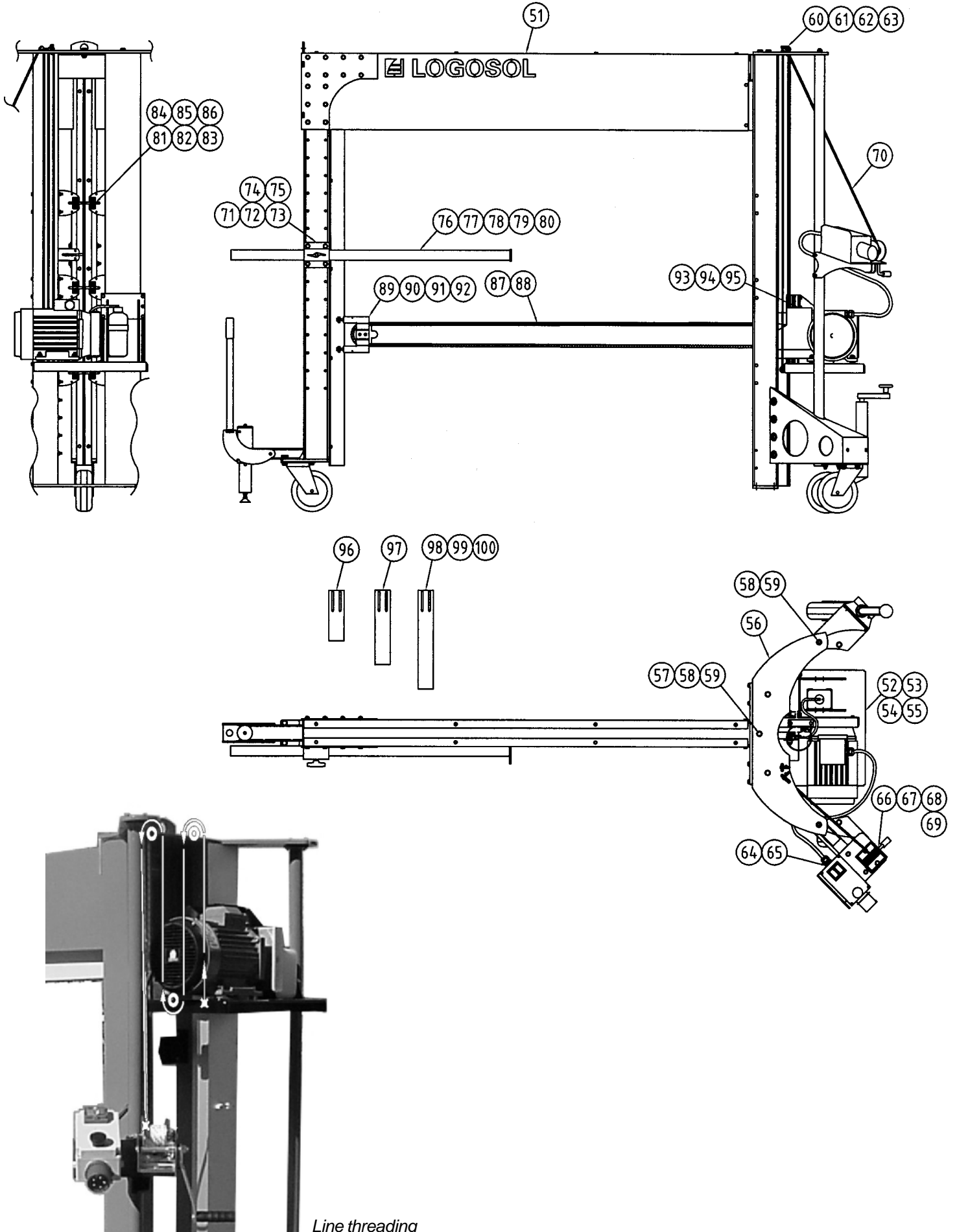

| Part no. | Number | Designation | Information | Article number |
|----------|--------|-----------------------|-----------------------|----------------|
| 51 | 1 | Stand | Pk-01-03 | |
| 52 | 1 | Cmpl. motor bracket | Pk-02 | |
| 53 | 1 | Cmpl. motor unit | Pk-09 | |
| 54 | 8 | Round washer | Brb 125A 10.5 | 0000-800-0020 |
| 55 | 4 | Locking nut | 985 M10 FZB | 0000-500-0007 |
| 56 | 1 | Top plate | Pk-17-5 | |
| 57 | 4 | Hexagonal bolt | M6S 933 M10x30 FZB | 0000-200-0027 |
| 58 | 6 | Round washer | Brb 10.5x22x2 Fzb | 0000-800-0008 |
| 59 | 3 | Locking nut | 985 M10 Fzb | 0000-500-0007 |
| 60 | 2 | Sheave holder | 777-4625-V | 4507-001-1205 |
| 61 | 2 | Sheave E | 700-3003 | 9999-000-6048 |
| 62 | 2 | Spacer sleeve 8/6/10 | 888-1020 | 4510-723-2511 |
| 63 | 2 | Locking nut | 985 M6 Fzb | 0000-500-0001 |
| 64 | 4 | Hexagonal bolt | M6S 933 M5x12 Fzb | 0000-200-0034 |
| 65 | 4 | Round washer | Brb 125A 5.3x10x1 Fzb | 0000-800-0019 |
| 66 | 1 | Winch | 900 lb/409 kg DL02796 | |
| 67 | 2 | Hexagonal bolt | M6S 933 M8x20 Fzb | 0000-200-0011 |
| 68 | 4 | Round washer | Brb 125A 8.4 Fzb | 0000-800-0002 |
| 69 | 1 | Locking nut | 985 M8 Fzb | 0000-500-0002 |
| 70 | 1 | Line 6 mm | 6.5 m | |
| 71 | 1 | Protective metal ring | | |
| 72 | 1 | Wing-headed bolt | 715 70- M8x15 | |
| 73 | 4 | Hexagonal bolt | M6S 931 M8x120 FZB | 0000-200-0030 |
| 74 | 8 | Round washer | Brb 125A 8.4 Fzb | 0000-800-0002 |
| 75 | 1 | Hexagonal nut | M6M 934 M8 Fzb | 0000-500-0006 |
| 76 | 1 | Sighting rod | Pk-03-v2 | |
| 77 | 1 | Sight peg | Pk-12, pos 4 | |
| 78 | 1 | Yoke | Pk-12, pos 3 | |
| 79 | 2 | Locking nut | 985 M6 Fzb | 0000-500-0001 |
| 80 | 2 | Round washer | Brb 125A 6.4 Fzb | 0000-800-0003 |
| 81 | 6 | Sight | Pk-12, pos 1 | |
| 82 | 6 | Sight peg | Pk-12, pos 4 | |
| 83 | 6 | Yoke | Pk-12, pos 3 | |
| 84 | 24 | Locking nut | 985 M6 Fzb | 0000-500-0001 |
| 85 | 36 | Round washer | Brb 125A 6.4 Fzb | 0000-800-0003 |
| 86 | 12 | Hexagonal bolt | M6S 931 M6x120 FZB | 0000-200-0029 |
| 87 | 1 | Guide bar | | |
| 88 | 1 | Chain | | |
| 89 | 2 | Cmpl. tip control | Pk-08 | |
| 90 | 4 | Round washer | Brb 5.3 | |
| 91 | 2 | Hexagonal bolt | M5x20 | |
| 92 | 2 | Locking nut | M5 | |
| 93 | 1 | Flexible chip duct | | |
| 94 | 2 | Hexagonal bolt | M6S 933 M6x20 | 0000-200-0001 |
| 95 | 2 | Round washer | Brb 125A 6.4 Fzb | 0000-800-0003 |
| 96 | 1 | Tip guard | Pk-19, l = 200 | |
| 97 | 1 | Tip guard | Pk-19, l = 295 | |
| 98 | 1 | Tip guard | Pk-19, l = 390 | |
| 99 | 2 | Hexagonal bolt | M6S 933 M6x20 | 0000-200-0001 |
| 100 | 2 | Round washer | Brb 125A 6.4 Fzb | 0000-800-0003 |

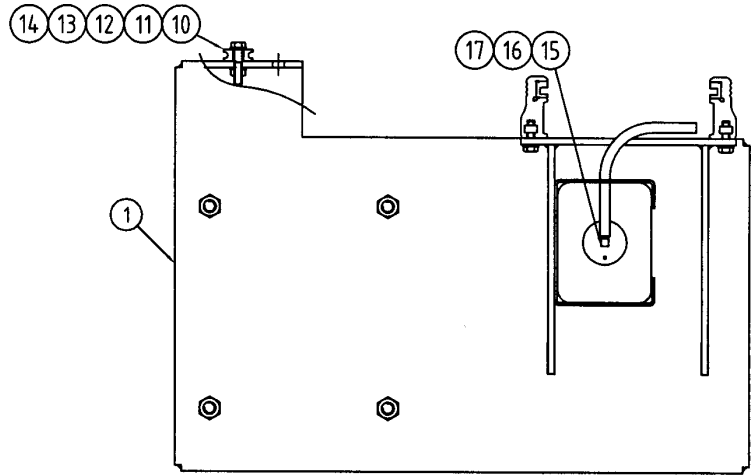
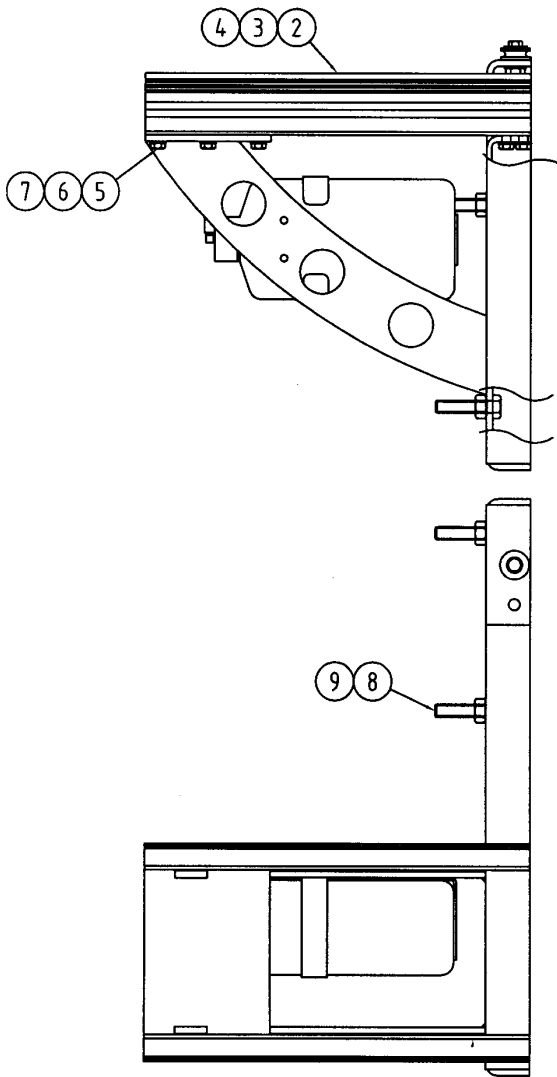

| Part no. | Number | Designation | Information | Article number |
|----------|--------|---------------------------|-------------------|----------------|
| 1 | 1 | Motor bracket | pk-02-04 | |
| 2 | 1 | Sledge strip, stack-cut | pk-02-05 | |
| 3 | 2 | Slide strip, stack-cut | | |
| 4 | 4 | Bolt R6B 7504 K B6x19 Fzb | | |
| 5 | 10 | Hexagonal bolt | M6x20, DIN 933 | |
| 6 | 10 | Washer | Brb 6.4 | |
| 7 | 10 | Square nut | M4M M6 | |
| 8 | 4 | Hexagonal bolt | M10x45 | |
| 9 | 4 | Hexagonal nut | M10 | |
| 10 | 1 | Sheave | | |
| 11 | 1 | Spacer sleeve 10/6/10 | R-723-2505 | |
| 12 | 1 | Hexagonal bolt | DIN EN24014 M6x30 | |
| 13 | 1 | Hexagonal locking nut | M6 | |
| 14 | 2 | Washer | Brb 6.4 | |
| 15 | 1 | Oil tank | | 9999-000-6052 |
| 16 | 1 | Oil tank holding plate | 700-4050 | |
| 17 | 1 | Cmpl. oil cap with mesh | | 9999-000-6054 |

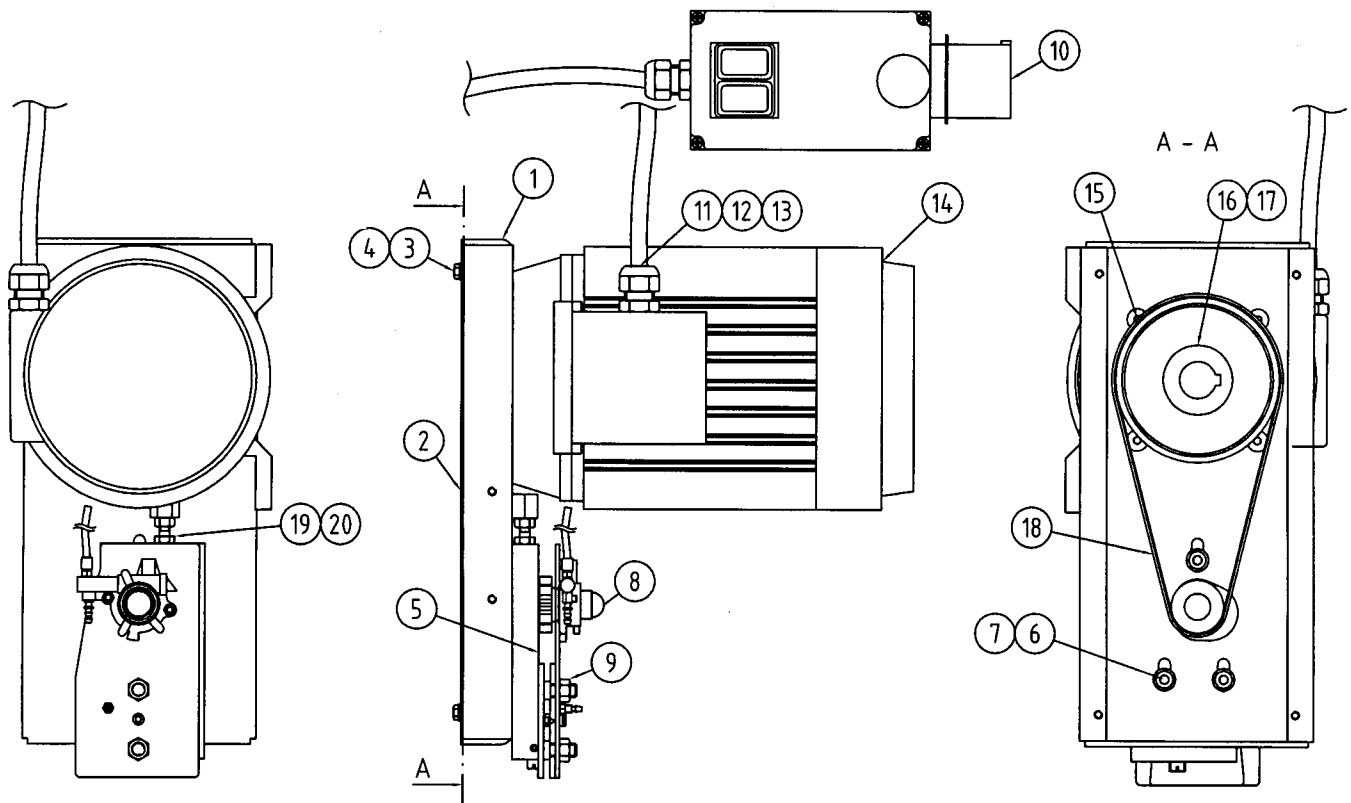

| Part no. | Number | Designation | Information | Article number |
|----------|--------|----------------------------------|--------------------|----------------|
| 1 | 1 | Motor plate | Pk-05 | |
| 2 | 1 | Motor plate lid | Pk-05-01 | |
| 3 | 4 | Hexagonal bolt | M6S 933 M6x20 Fzb | 0000-200-0001 |
| 4 | 4 | Round washer | Brb 125A 6.4 Fzb | 0000-800-0003 |
| 5 | 1 | Cmpl. bearing housing with shaft | Pk-04 | |
| 6 | 3 | Socket head cap bolt | MC6S 912 M8x25 | 0000-100-0005 |
| 7 | 3 | Round washer | Brb 125A 8.4 | 0000-800-0002 |
| 8 | 1 | Cmpl. cover plate | Pk-06 | |
| 9 | 2 | Locking nut | 985 M10 Fzb | 0000-500-0007 |
| 10 | 1 | Electrical connector | 9999-000-6075 | |
| 11 | 1 | Check nut | Skindicht SM 13.5 | 9999-000-6059 |
| 12 | 1 | Enlarger | Skindicht ME | 9999-000-6059 |
| 13 | 1 | Adapter for thick cable | Skintop PG 16 | 9999-000-6061 |
| 14 | 1 | Electric motor 5 kW | 8502-001-0005 | |
| 15 | 1 | Countersunk socket head cap bolt | MF6S 916 M8x10 Fzb | 0000-300-0002 |
| 16 | 1 | Pulley 28/125 | 700-3001-1 | 9999-000-6026 |
| 17 | 1 | Stop bolt | SK6SS 916 M8x10 | 0000-000-0002 |
| 18 | 1 | Poly V-belt | 9999-000-6000 | |
| 19 | 1 | Hexagonal bolt | M6S 933 M8x30 | |
| 20 | 1 | Nut | M8 | |

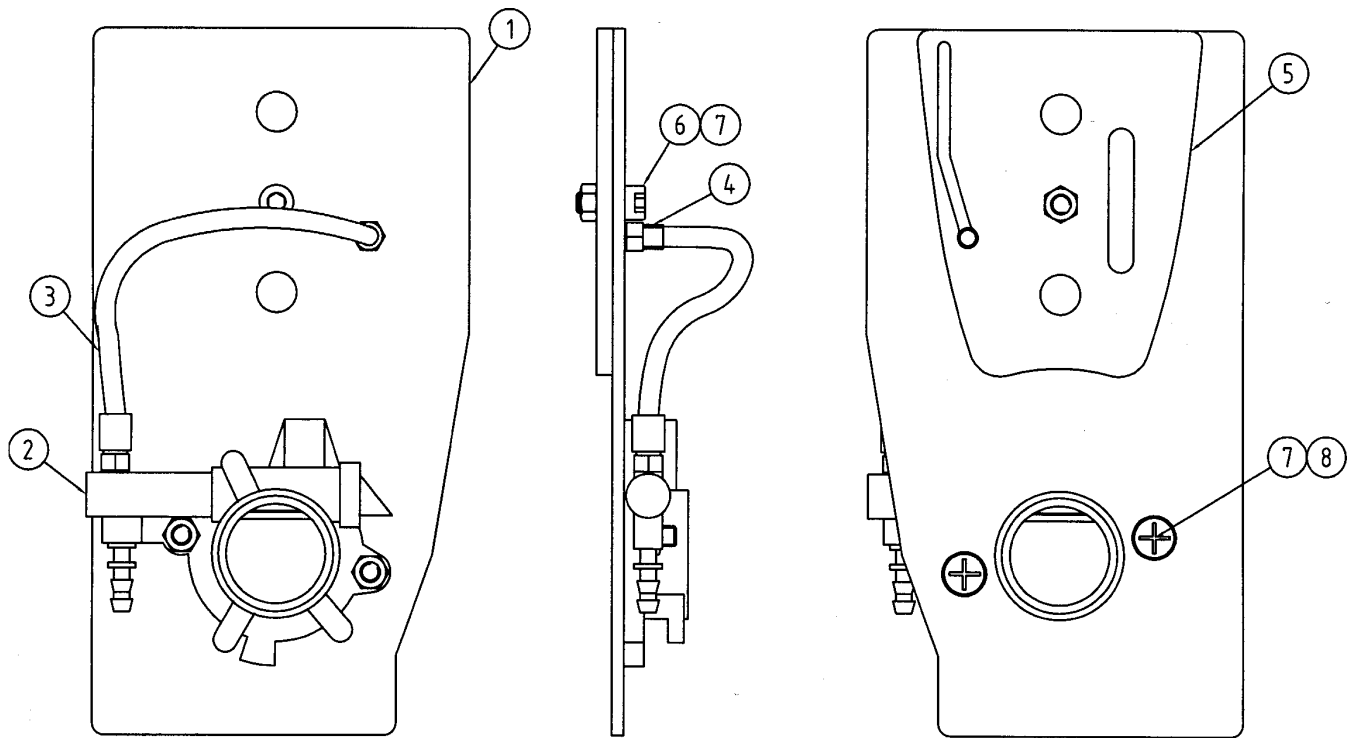

| Part no. | Number | Designation | Information | Article number |
|----------|--------|------------------------|-----------------|----------------|
| 1 | 1 | Cover plate | Pk-06-v2 | |
| 2 | 1 | Oil pump | | 9999-000-6020 |
| 3 | 1 | Transp. oil hose | | 9999-000-6036 |
| 4 | 1 | Nipple | | 9999-000-6018 |
| 5 | 1 | Guide bar upper washer | Pk-10-v3, pos 2 | |
| 6 | 1 | Socket head cap bolt | MC6S M5x12 | |
| 7 | 3 | Locking nut | 985 M5 | 0000-500-0009 |
| 8 | 1 | Star-headed bolt | M5x16 | 9999-000-6002 |

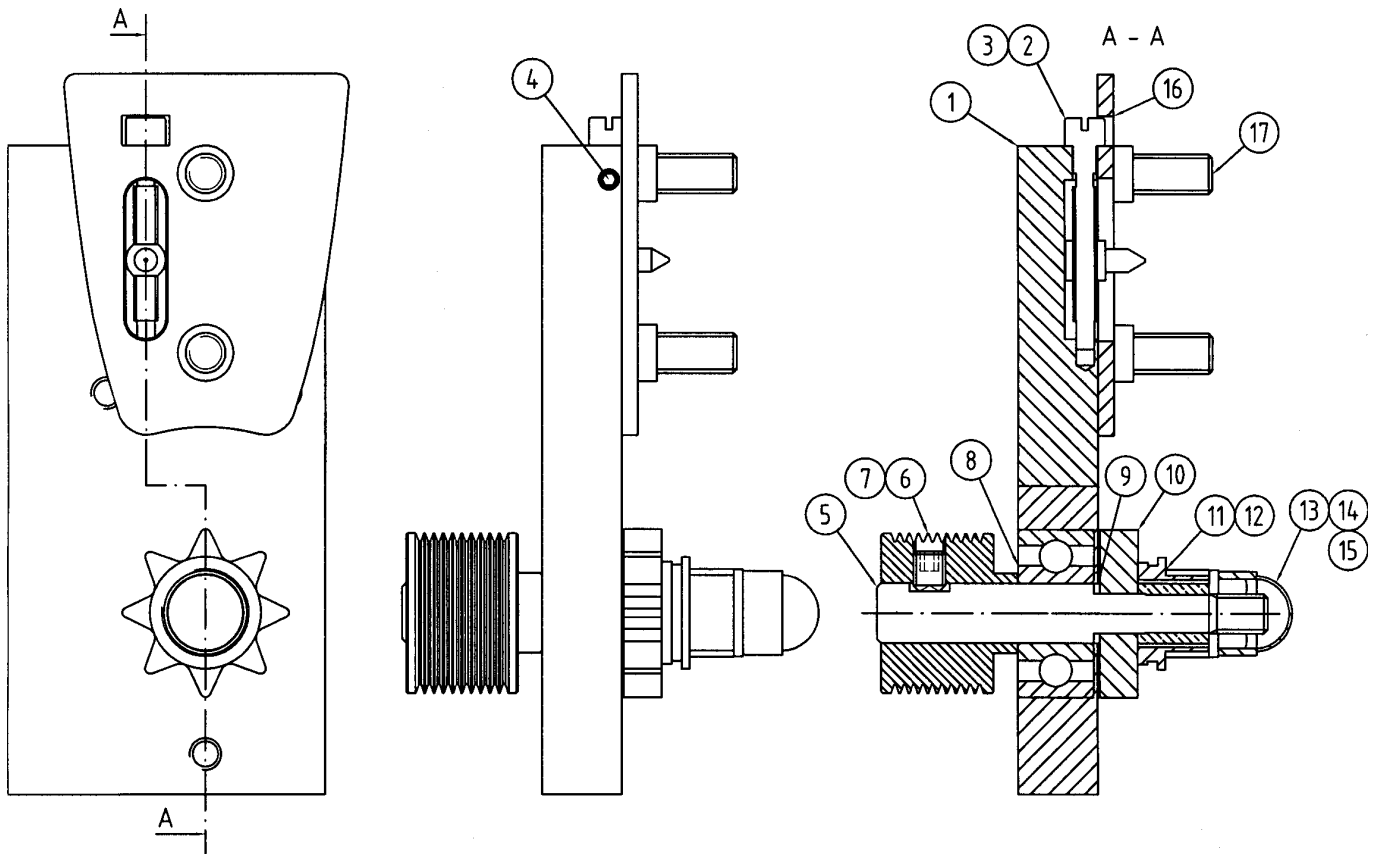

| Part no. | Number | Designation | Information | Article number |
|----------|--------|----------------------------|------------------------|----------------|
| 1 | 1 | Bearing housing, stack-cut | Pk-04-1 | |
| 2 | 1 | Chain tensioner bolt | 501 79 27-01 Husqvarna | |
| 3 | 1 | Tensioning pin | 501 22 68-01 Husqvarna | |
| 4 | 1 | Stop bolt | T6SS DIN 915 M5x16 | |
| 5 | 1 | Shaft | 700-2001 | 9999-000-6066 |
| 6 | 1 | Pulley 15/40 | 700-3001-1 | 9999-000-6025 |
| 7 | 1 | Ball-headed thrust bolt | DIN 916 - M 8 x 10 | |
| 8 | 1 | Ball bearing | | 9999-000-6067 |
| 9 | 1 | Retaining ring | RS009 6799 Fzb | 0000-950-0004 |
| 10 | 1 | Chain sprocket | 3/8"-8 | 1207-642-1310 |
| 11 | 1 | Oil pump sprocket | Plastic | 9999-000-6021 |
| 12 | 1 | Rubber bushing | | 9999-000-6069 |
| 13 | 1 | Washer NB steel 1300 | 10x19x1.5 Fzb | 0000-800-0013 |
| 14 | 1 | Locking nut | 985 M10 Fzb | 0000-500-0007 |
| 15 | 1 | Plastic cover | | 9999-000-6030 |
| 16 | 1 | Guide bar lower washer | Pk-10-v3, pos 1 | |
| 17 | 2 | Guide bar bolt | Pk-20 | |

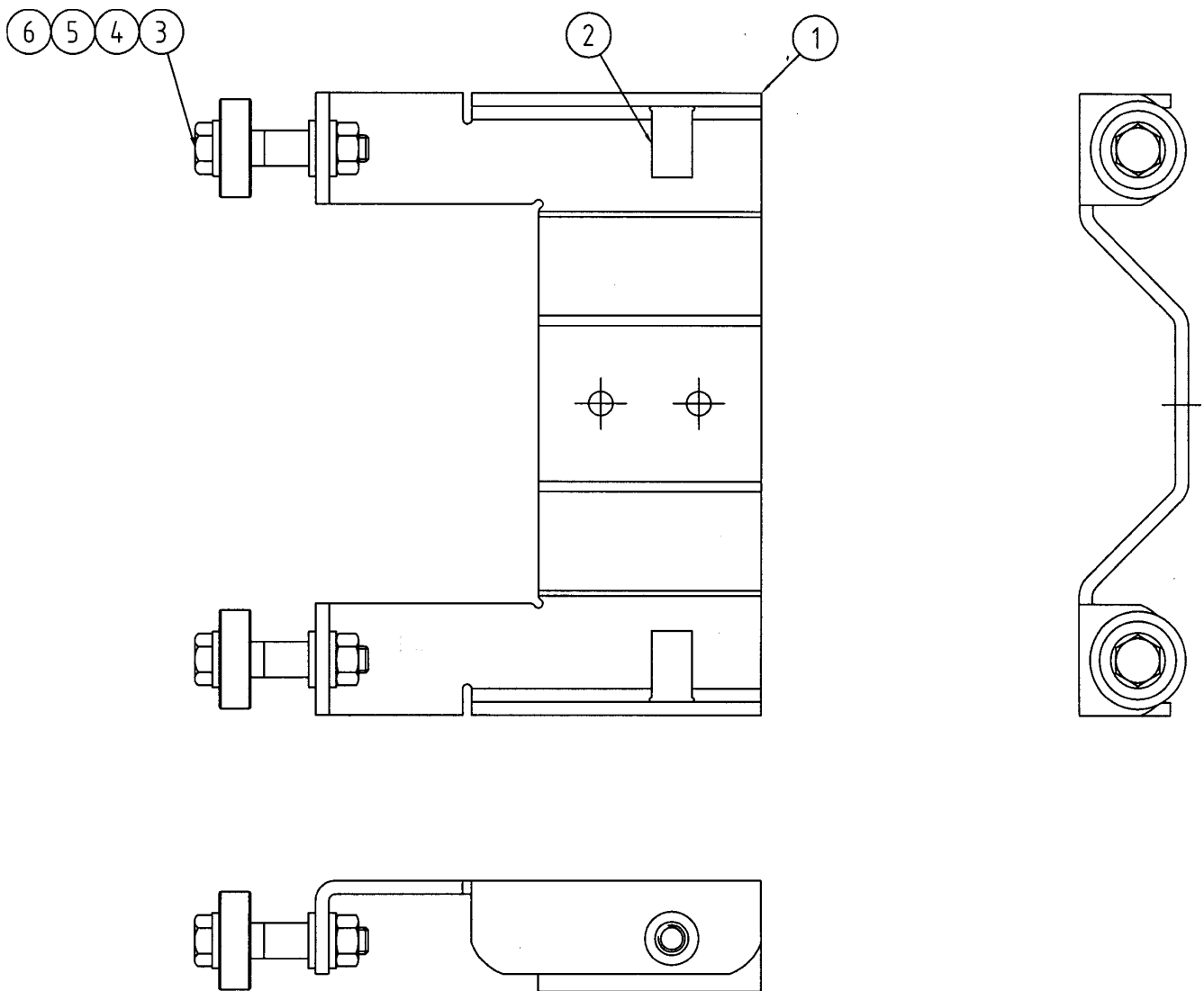

| Part no. | Number | Designation | Information | Article number |
|----------|--------|-----------------------------|---------------|----------------|
| 1 | 1 | Guide bar tip control | Pk-08-1 | |
| 2 | 2 | Threaded sleeve, Pop-nut M6 | UFO 65 | |
| 3 | 2 | Hexagonal bolt | M6S 933 M6x35 | 0000-200-0013 |
| 4 | 6 | Round washer | Brb 125A 6.4 | 0000-800-0003 |
| 5 | 4 | Spacer sleeve 8/6/10 | 888-1020 | 4510-723-2511 |
| 6 | 2 | Locking nut | 985 M6 FZB | 0000-500-0001 |

Adjusting guide bar alignment

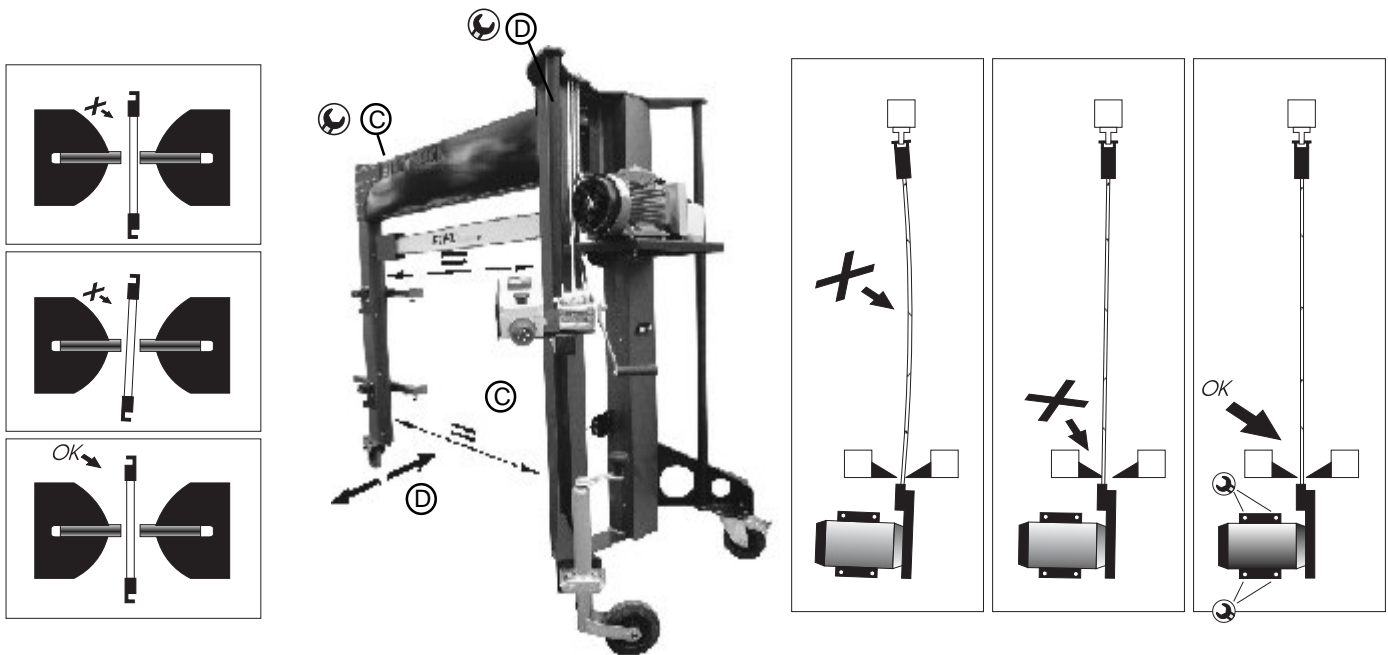

Schematic sketches of the machine's sighting rod on the motor side and the saw unit seen from above. "⊗" shows incorrect adjustment, "OK" shows correct adjustment. This symbol "↗" shows where to adjust.

Adjusting the stand

Stack Cutter has to be adjusted after assembly.

⚠ Before starting adjustment, disconnect the machine's power supply.

The ball bearings for controlling the guide bar's tip are located in oblong cut-outs. Set the ball bearings to their outermost position so that there is play around the T-profile (2).

A. With the motor unit in the top position, adjust guide bar alignment as per the sketches above. The guide bar must be positioned halfway between, and parallel with, the machine's two front legs (14) on the motor side. In the top position, the T profile (2) must also sit halfway between the guide bar tip's ball bearings. The bearings must not push against the T-profile on either side.

B. Tighten the bolts holding the motor unit.

- C. Lower the motor unit and adjust the rear leg's distance from the guide bar tip. During adjustment, loosen the bolts (12-13) that hold the beam. The ball bearings should run in a straight line parallel with the T-profile.
- D. Adjust the rear leg's lateral angle (i.e. right/left alignment). During adjustment, loosen bolts 15-16. Just as when the motor was in the top position, the ball bearings at the tip of the guide bar must not push against the T-profile on either side.
- E. Check that all the bolts in the stand are tightened.
- F. Set the ball bearings at the tip of the guide bar so that they push against the T-profile.

Circuit diagram

⚠ Potentially lethal voltage! Faulty connection can result in a fatal accident.

❗ Note that only qualified electricians are authorised to open or work on the machine's electrical equipment. Ensure that the power is disconnected before exposing any part of the electrical system.

❗ Connect the machine and check that the motor is running in the right direction. If it is not, pull the plug out of the machine. Switch the phases in the plug by using a large flat screwdriver to turn the disc (6) that holds two of the pins.

⚠ Under current regulations, the machine must be connected via a 5-flex cable (7). It must not be switched on if the power connection does not have a separate earth and a separate neutral.

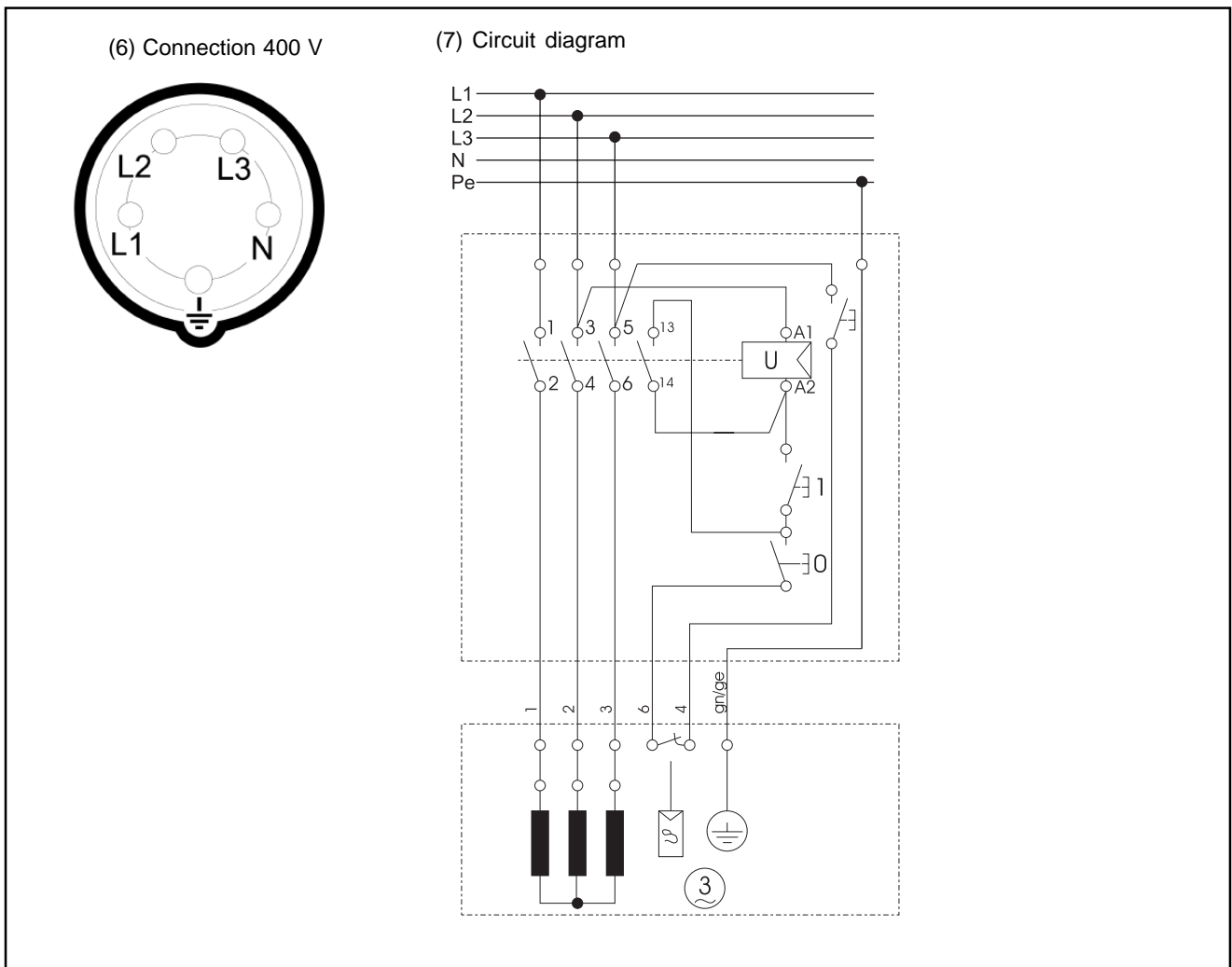

Technical data, *Stack Cutter* 1200/1500

| | | |
|--|---------------------------------|--------------------------------|
| <i>Dimensions</i> <i>Stack Cutter 150</i> | Length | 2,600 mm |
| | Width | 1,100 mm |
| | Height | 1,900 mm |
| | Weight | 145 kg |
| <i>Cutting dimensions</i> <i>Stack Cutter 150</i> | Max. stack width | 1,400 mm |
| | Theoretical max. width approx. | 1,450 mm |
| | Max. stack height | 1,350 mm |
| | Rec. height off ground | 150 mm |
| | Max. total stack height | 1,500 mm |
| <i>Dimensions</i> <i>Stack Cutter 120</i> | Length | 2,300 mm |
| | Width | 1,100 mm |
| | Height | 1,900 mm |
| | Weight | 135 kg |
| <i>Cutting dimensions</i> <i>Stack Cutter 120</i> | Max. stack width | 1,100 mm |
| | Theoretical max. width approx. | 1,150 mm |
| | Max. stack height | 1,350 mm |
| | Rec. height off ground | 150 mm |
| | Max. total stack height | 1,500 mm |
| <i>Chip handling</i> | Chip duct | 100 mm |
| | Required min. chip fan capacity | 700 m ³ /h |
| <i>Electrical system</i> | Power supply | CCA16 A, 400 V, 50 Hz, 3-phase |
| | Protection class | IP54 |
| | Motor power rating | 5 kW |
| <i>Sound levels</i> | Sound pressure level | 102.0 dB (A) |
| | Sound power level | 113.0 dB (A) |
| <i>Cutting equipment</i> | Chain pitch | 3/8 inches |
| | Chain speed | 22.5 m/sec |

EU declaration of conformity

EU declaration of conformity in accordance with Machinery Directive 98/37/EC, Annex II A.

Manufacturer, LOGOSOLAB, Industrigatan 13, SE-871 53 Härnösand, tel. +46 (0)611 18285, hereby declares that *Stack Cutter*, art. no. 8540-000-0150 is manufactured in accordance with the following directives:

Machinery Directive 98/37/EC, EMC Directive 89/336/EEC and the Low Voltage Directive 73/23/EEC.

Härnösand, 1 January 1995



MD Bengt-Olov Byström



LOGOSOL Sverige

Industrigatan 13

Telefon 0611-182 85

<http://www.logosol.se>

SE-871 53 Härnösand

Telefax 0611-182 89

info@logosol.se

LOGOSOL USA

P.O.box 660

Phone 601-856 18 89

info@logosol.com

Madison Mi 391 30

Fax 601-856 95 35

<http://www.logosol.com>

LOGOSOL Deutschland

Mack Strasse 39

Telefax 07581-506462

info@logosol.de

DE-88348 Bad Saulgau

Telefon 07581-506460

<http://www.logosol.de>