



Kellfri[®]

21-TK15F

WOOD CHOPPER GRAPPLE



READ THIS MANUAL CAREFULLY BEFORE USING THE PRODUCT !!!

TRANSLATED FROM THE ORIGINAL

Contents

Introduction 3
Product information 3
Intended use 3
Safety information 4
Product safety information 4
Instructions for emergencies 4
Warning labels 5
Personal protection 5
Surroundings 6
Before use 6
Use 7
After use 7
Storage 7
Maintenance and service 8
Service intervals 8
Recycling 8
Link pins 9
Complaint form 11
Warranty and EC declaration of conformity 12

INTRODUCTION

Thank you for choosing a product from Kellfri AB. By following the general safety information and the instruction manual and by using common sense, you will have a great and safety use of your Kellfri product for many years. Kellfri designs and delivers effective, affordable machinery and components for forest, agriculture, construction and gardening in Sweden, other Nordic countries and Europe.

PRODUCT INFORMATION

Wood chopper grapple with fixed blade, powerful single grapple and minimal weight. Flexible and easy-to-manoeuvre chopper grapple that makes it easy to get to timber, even saplings are easily cut as it can cut slender trunks up to 15 cm. Fast chopping sequence for top felling performance. Linked to the rotator and connected to the grapple's normal hydraulic hoses.

Adjustable sequence valve manages tilt up/down excluding the need for additional hoses except those for opening/closing the grapple. 50 mm opening for rotator connection, 3/8" thread for hydraulic hoses and replaceable blade. A flexible and fast energy grapple that suits most cranes and requirements.

INTENDED USE

The equipment is intended for cutting and gripping shrubs and timbers

TECHNICAL DATA	21-TK15F
System pressure	175-210 bar
Grapple	650 mm
Rotator attachment	50 mm
Cutting width, trunk	(max) 150 mm
Weight	132 kg
Hydraulic system flow	25-50L/min

FOR YOUR SAFETY

Before using the product, please read the safety information and instruction manual and understand its contents for your own and others' safety. Always keep the safety information and instruction manual easily accessible to the user of the product. Remember that it may be good for your own and others' safety to read the safety information every now and then. If the instructions manual is damaged or otherwise unusable, please contact your retailer and order a new one

The general safety instruction is also available from Kellfri's website: www.kellfri.com

Do not use this equipment if you are feeling sick, tired or in influence of alcohol. Nor if you are under the influence of strong medications or drugs, suffering from strong depression or severe mental illness. Always follow the general traffic rules and regulations and the rules of the Animal Welfare Act. Persons under 15 years old and people with mental illness may not use this product.

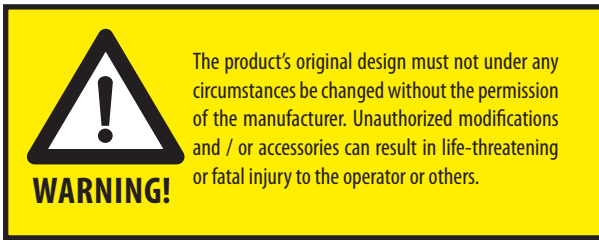

PRODUCT SAFETY

The wood chopper grapple is only suitable for timber cranes with rotator NOT to be mounted onto excavator or other machine with fixed mounting. The tractor must be equipped and suitable for handling timber and approved for the purpose. Forestry trailer must be CE marked. When the base machine is overloaded, the load could fall uncontrollably, Do not overload! The equipment should always be operated from the cab of the tractor. Never leave the tractor until the equipment is unloaded and the tractor braked is applied. Keep bystanders of the danger zone -25 m. No one other than the operator may be in the vicinity during work. The operator or other person are never allowed to stand in any circumstances under suspended loads.









INCASE OF EMERGENCIES

In case of an emergency please dial 112.

Keep cell phone or emergency phone available specially when working alone. First aid kit and fire extinguishers must be kept easily accessible during all work, maintenance and service.

WARNING SIGNS AND LABELS

Ensure that warning labels are always visible and clean. Clean the warning labels as required. Do not rinse using pressure washer directly on the warning labels. Any damage/ broken stickers should be replaced. Order new stickers from your supplier.

Symbol	Explanation
	Danger zone
	Max load 400kg (cranes max loading capacity)
	Warning! Suspended load
	Warning! risk of crushing
	Read the instruction manual
	The product is CE- marked

PERSONAL PROTECTION

Always wear suitable clothing and footwear. Do not wear loose clothing or jewelry when using the machine. Remember to put up long hair when operating rotating machines. Wear protective gloves, to prevent risking burns on contact with hot surfaces such as exhaust system, and to avoid oil and gasoline on the skin. Hearing protection should be used when the engine is running. Eye protection and protection mask should be use when necessary.



SURROUNDINGS

Always use caution when operating the machine.

Check and make sure that the area is clear of people, children and objects before switching on or using the equipment. Risk of serious personal injury. Be especially careful if children are in the area where the equipment is being use or stored. Check that there are no low-hanging power lines within the work area. Be careful when working on slopes and near ditches. Always work alone with equipment designed for single - purpose tools/products. Never have junk/debris lying in your work area. Have workspaces clean. Always respect the risk zone.



BEFORE USE

Read the safety information and operating instructions carefully. Be sure that you understand the safety information, operating instructions and warning labels. Use common sense when using the machine and use appropriate personal protective equipment. Always check the performance and the machine combination that are use. It's highly important these matches in a satisfactory manner. This is to ensure the product or the function and most important yours and others safety. Visually inspect the equipment or product before using it. Fix or replace damaged or worn parts immediately to reduce the risk of injury.

Lubricate moving parts and check that all nuts and bolts are tightened. Learn and remember correct working method. Beginners should keep a low speed until the person has learned how the machine works. The user / customer is responsible to handle the situation correctly. Do not use the machine if it is experienced to be dangerous for the user. Read the User's manual before connecting the machine.

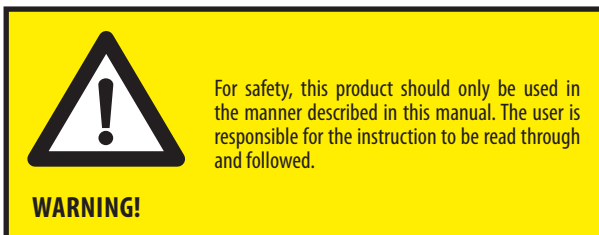

OPERATION

Only people who understand the safety information and instruction manual to operate this equipment. Be alert and careful when working with the equipment and only use the equipment in the manner described in the instruction manual. Avoid using of the equipment at temperatures lower than -20 ° C and higher than 30 ° C.

Check that the equipment is undamaged before connecting it to the crane. Connect the equipment and lock it in place. Regularly check the locking pin of the machine to the crane rotator. Disconnect the hydraulic hoses and ensure that they do not rub or get pinch against any obstacle. The rotator must always hang freely and vertically in the direction of the axle. The link pins must be locked in place using clip pins. Read through tractors and forestry trailer manual before driving.

Exercise caution when working with equipment with hydraulic hoses as oil under pressure can penetrate the skin. If this should occur please seek medical attention immediately.

Hydraulic system might not be 100% tight, the hydraulic control must be performed before the equipment is use. Leakage can be due to internal leakage in the tractor valve, electric valve on the front loader, internal leakage in the equipments hydraulic cylinder etc.. Check the extent of the leakage by running the equipments cylinder to it's end positions and keep up the pressure for 1 min. If the cylinder begins to "move" the other way, theres a leakage on the gasket inside the cylinder. The gasket or cylinder must be replaced.

Always work alone with the tools that are destined for this. Never overload the equipment and respect the risk zone.

AFTER USE

Parking is not allowed with the equipment above ground, only with the equipment resting on the ground. Rinse the implement if necessary.

STORAGE

Always store the tool or product in a dry place preferably under cover when not in use. Ensure that the tool or product is stable and not likely to tip over. Never let children play at the storage site. Keep in mind the risk of tipping!

MAINTENANCE AND SERVICE

Make sure the trailer is stable and cannot tip over when carrying out maintenance and service work. Replace damaged or worn parts to reduce the risk of injuries. Carry out maintenance, service and checks with recommendations. Only use spare parts with equal performance to reduce the risk of injuries and breakdowns. Check all bolts and nuts are tightened after maintenance and service. Always test the machine before starting any operation.

IMPORTANT ! Replace loose bushings immediately! Backlash in the spring can lead to damage of the machine.

SERVICE INTERVALS / MAINTENANCE

Lubricate moving parts and check that all nuts and bolts are tightened before each use. Replace or sharpen the knife at noticeable wear.

RECYCLING

Disposal of the product, disassemble and transport to the municipality's recycling station. Contact your local authority for further information.

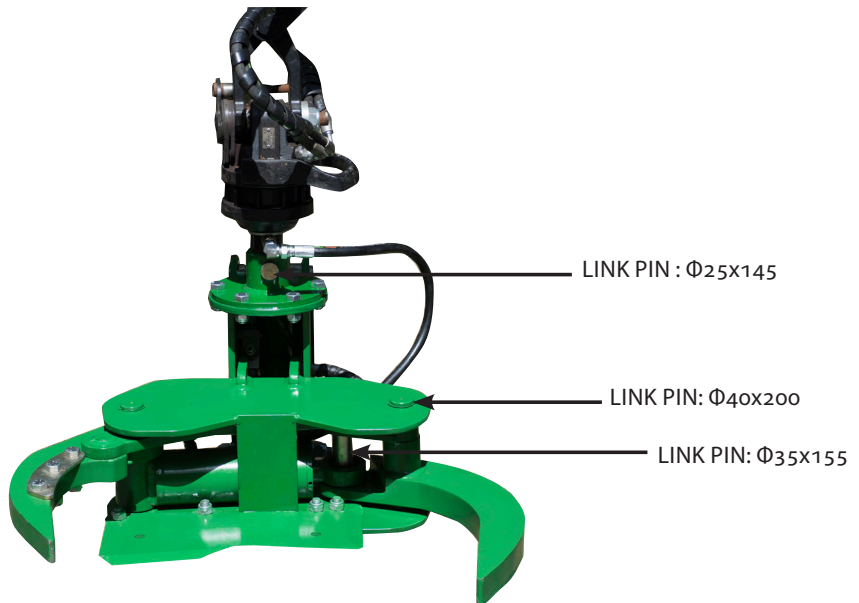
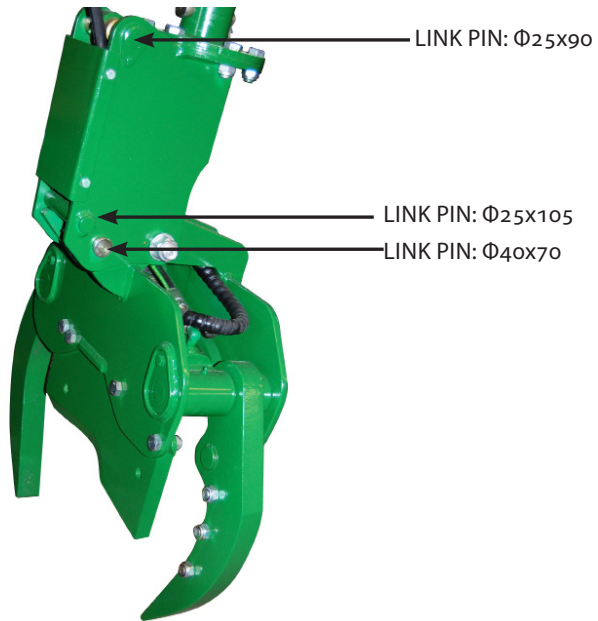

When cutting big trunks up to 150mm, the trunk should rest on the side of the knife next to the grapple's claw. When cutting bushes and shrubs, the strains can be placed straight across the blade.

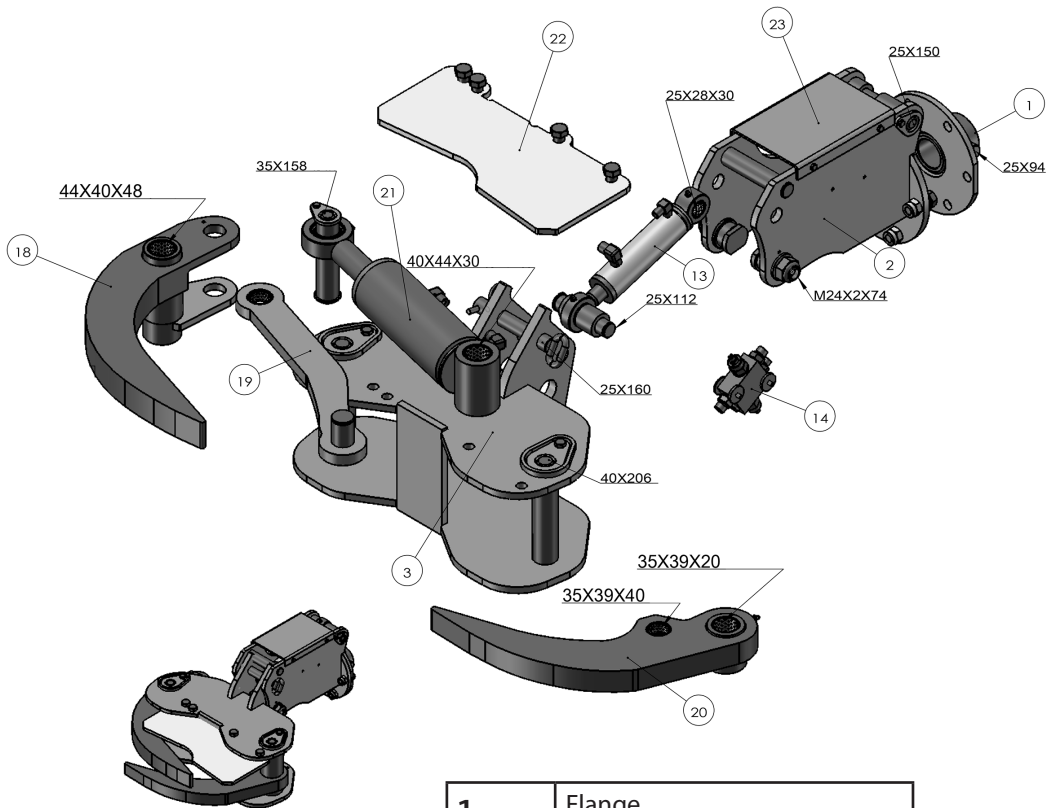

1	Flange
2	Head
3	Body
13	Tilt cylinder
14	Valve package
18	Claw - left
19	Tie Rod
20	Claw - right
21	Grapple Cylinder
22	Knife
23	Cover plate

We are grateful for your help pointing out any inaccuracies in the Kellfri product delivered to you. Before making a complaint read Kellfris general warranty and sales conditions in our catalog as well as the enclosed User's manual that comes with the machine.

Please fill in the details below and attach photo in order to process your request.

Buyer:	Customer number:
Address:	Invoice number:
E-mail:	Phone nr:

When was the product delivered?	When was the product taken into operation?	Did the product function as it should upon the first operation?
---------------------------------	--	---

Defect product / part:

.....

Problem description:

.....

.....

Describe the sequence of events:

.....

.....

.....

.....

.....

.....

.....

.....

Other:

.....

.....

Send Complaint form and photo to: (contact your rretailer)

Kellfri AB

Division of Services

Munka Torpgatan 6

532 37 Skara

Or mail service.

info@kellfri.se

Signature:	Date:
------------	-------

KELLFRI AB

Munka Torpgatan 6

SE-532 37 Skara

Phone: +46 (0)511-242 50

Fax: +46 (0)511-168 33

Web

www.kellfri.com

E-mail

info@kellfri.se

Issue: 2014-01-01

WARRANTY TERMS AND CONDITIONS

Validity of the warranty - Kelifri's Warranty is valid 12 months from the date of purchase.

This warranty replaces - Compensation for spare parts after acknowledgment that the fault lies on the material or manufacturing defects.

This guarantee do not cover

- Labour costs
- Travel expenses
- Any modification that the buyer himself has/had made.
- Any consequential damages that occurred out of damage to the machine.
- Damage due to normal deterioration of the machine, inadequate service, user inexperience or use of spare parts which are not original.
- Wear parts such as hoses, seals, oils, and mechanical belts

CE EC DECLARATION OF CONFORMITY MACHINE, ORIGINAL

EC-DECLARATION OF CONFORMITY

According to 2006/42/EC, Annex 2A

Kelffri AB

Munkatorpsgratan 6

532 37 Skara, Sweden

Declares that the machine

Name: 21-TK15F

Type: Wood chopper grapple

Complies with all applicable provisions of the Machinery Directive 2006/42/EC.

Other equipment must meet the requirements of the Directive.



Tina Baudtler, VD 2015-06-08

Kelffri AB is constantly working on further developing their products and therefore reserves the right to modify, among other things the design and appearance without notice.

CUSTOMER SERVICE

You are always welcome to give your feedbacks, reviews or ask us about our tools and products.

Kelffri AB

Telefon: 0046 (0) 511 - 242 50

Fax: 0046 (0) 511 - 168 33

E-post: info@kelffri.se



Kelffri[®]