

ENGLISH

Hakki Pilke

Easy 38

FIREWOOD PROCESSOR SPARE PARTS MANUAL



MAASELÄN KONE OY

Valimotie 1, FI-85800 Haapajärvi, Finland

Tel. +358 (0)8 772 7300, Fax +358 (0)8 772 7320

info@maaselankone.fi

www.maaselankone.fi

Contents

1.1	Exploded view of the machine.....	5
1.2	Machine parts list.....	6
1.3	Exploded view of the frame.....	7
1.4	Frame parts list.....	8
1.5	Exploded view of frame 2.....	9
1.6	Frame 2 parts list.....	10
2.1	Exploded view and parts list of the lower section of the out-feed conveyor.....	11
2.2	Exploded view and parts list of the upper section of the out-feed conveyor (37400).....	13
2.3	Exploded view and parts list of the out-feed conveyor (50016828).....	14
2.4	Exploded view and parts list of the belt of the out-feed conveyor (10317).....	15
3.1	Exploded view and parts list of the splitting valve kit (50008910).....	16
3.2	Exploded view and parts list of the in-feed conveyor extension (37631).....	17
3.3	Exploded view and parts list of the in-feed conveyor (37319).....	18
3.4	Exploded view and parts list of the tensioning roller of the in-feed conveyor (37524).....	19
3.5	Exploded view and parts list of the middle roller of the in-feed conveyor (37528).....	20
3.6	Exploded view and parts list of the pincher roll of the in-feed conveyor.....	21
4.1	Exploded view and parts list of the saw unit.....	22
4.2	Exploded view and parts list of the saw motor.....	23
4.3	Exploded view and parts list of the saw drive end.....	24
4.4	Exploded view and parts list of the saw unit cylinder (10242).....	25
5.1	Exploded view and parts list of the control panel.....	26
6.1	Exploded view and parts list of the log press (37600).....	27
7.1	Exploded view and parts list of the mechanical measuring device.....	28
7.2	Exploded view and parts list of the optical measuring device.....	29
7.3	Exploded view and parts list of the optical eye and casing.....	30
8.1	Exploded view and parts list of the filter.....	31
9.1	Exploded view and parts list of the splitting blade guard.....	32
10.1	Exploded view and parts list of the power transmission (the combi model, 37611).....	33
10.2	Exploded view and parts list of the power transmission (the tr model, 37632).....	34
10.3	Exploded view and parts list of the electric motor (Combi model).....	35
10.4	Exploded view and parts list of the electric motor (electric model).....	36
4.1	Exploded view and parts list of the splitting cylinder (37510).....	37
4.2	Exploded view and parts list of the splitting blade cylinder (60915).....	38
5.1	Figures and part numbers of the splitting blades.....	39

1.1 Exploded view of the machine

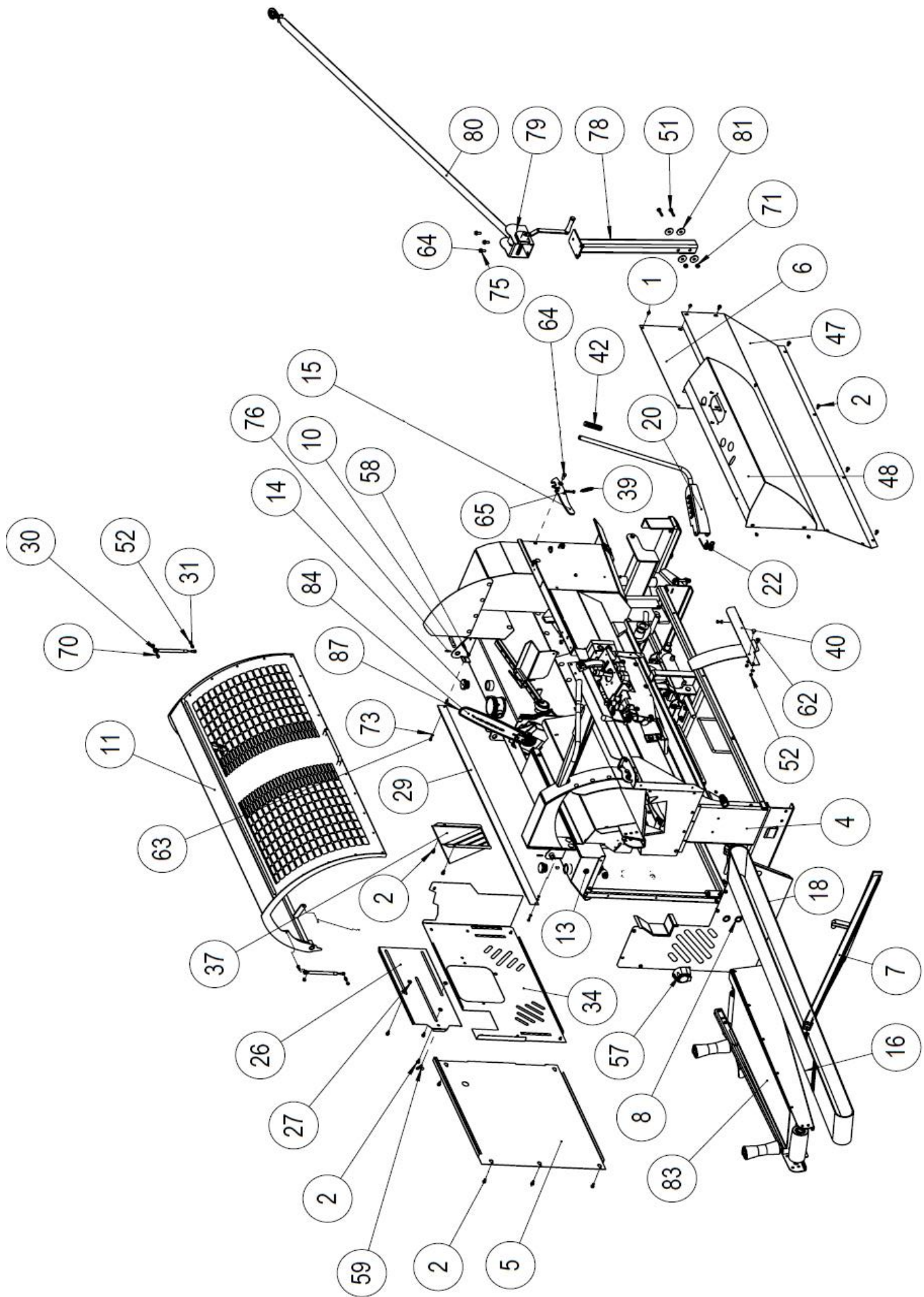

1.2 Machine parts list

No.	Part number_Name	Pcs
2	96172_Flange bolt M8x16	29
4	37374_Frame, tank and in-feed conveyor etc.	1
5	37455_Maintenance hatch	1
6	37463_Cover sheet	1
7	37390_In-feed conveyor support	1
8	97388_Quick coupling female 1.2 automatic	4
10	47967_Cage pin	2
11	37430_Upper guard	1
13	97446_Oil gauge	1
14	97429_Filler cap	2
15	47089_Out-feed conveyor locking latch	1
16	95128_In-feed conveyor belt	1
18	37283_End of the in-feed end	1
20	10815_Conveyor lock	1
22	95432_Double torsion spring	1
26	37513_Slide plate	1
27	37341_Insert	3
29	37447_Baffle board	1
30	95539_Gas pressure spring +95541 +95542	2
31	95550_Ball head with screw	2
32	37561_Wood length limiter	1
34	37340_Rear cover, electrically operated model	1
37	37551_Sawdust guide	1
39	95029_Draw spring Ø2x15 L=80	1
40	37546_Plate for the extra guard of the cutting blade	1
42	95034_Handle	1
47	37439_Front cover plate	1
48	37367_Control panel	1
51	96111_Hex screw 931/8.8ZN M12x90	2
52	96222_Lock nut DIN 985 M8	10
57	95201_Socket	1
58	96221_Lock nut DIN 985 M6	2
59	95264_Wing nut DIN 315 M8	1
60	96077_Spring pin DIN 1481 8x40	2
62	96187_Lock screw DIN 603 M8x20	2
63	96135_Hex screw DIN 933 M6x20	2
64	96139_Hex screw DIN 933 M10x25	13
65	96166_Hex screw DIN 933 M8x35	1
66	96150_Hex screw DIN 933 M12x60	1
70	96164_Hex screw DIN 933 M8x25	4
71	96218_Lock nut DIN 985 M12	9
73	96060_Washer DIN 125 A6	4
75	96049_Washer DIN 125 A10	17
76	96080_Spring pin DIN 1481 96080_6x30	2
78	10825_Fastening pipe for the winch	1
79	95412_Winch	1
80	95068_Winch strap with hook	1
81	96306_Washer DIN 440 M12	4
83	37631_In-feed conveyor extension	1
84	95147_Blade flange 16"	1
87	95416_Blade chain 67 links 0.325 1.5mm	1

1.3 Exploded view of the frame

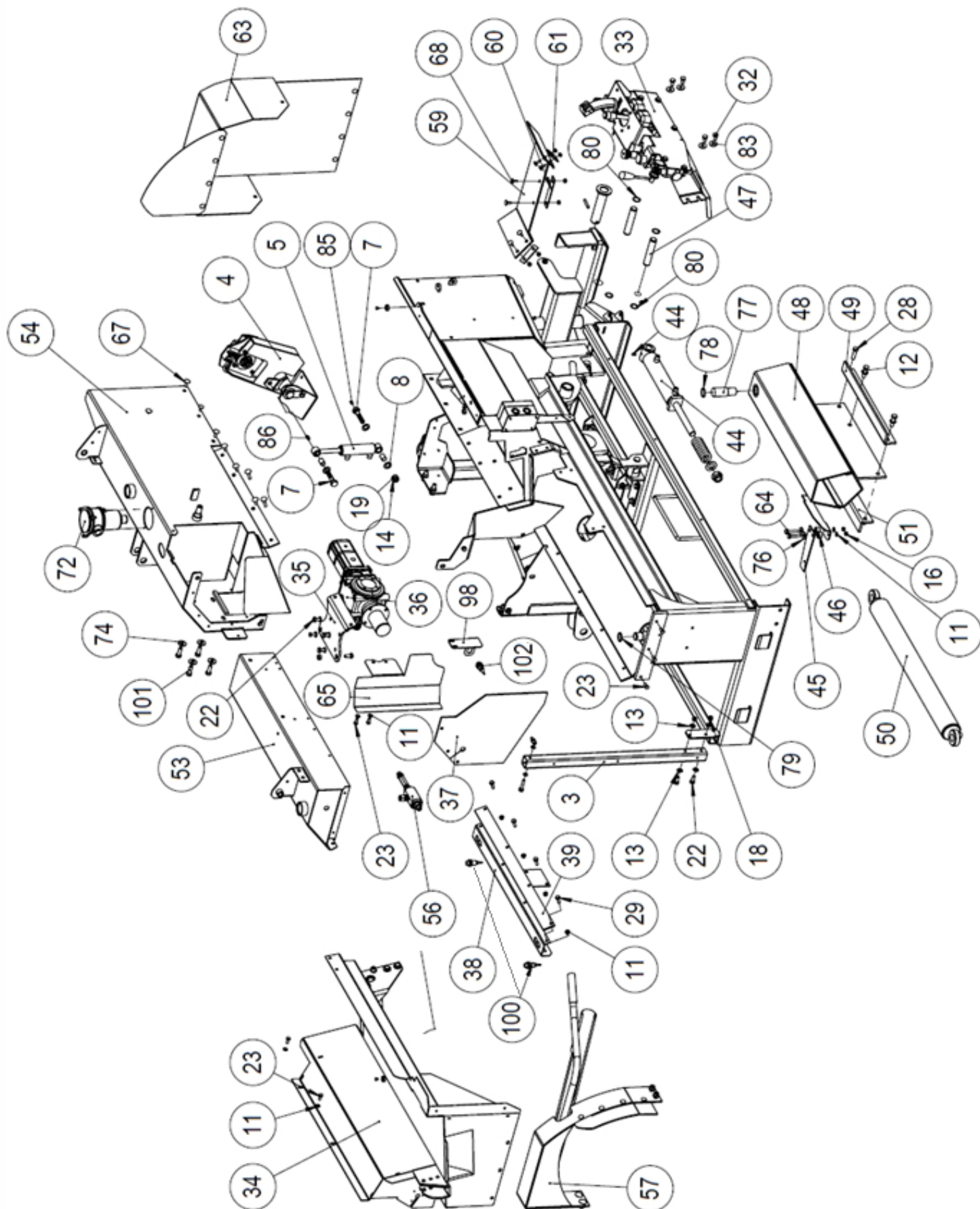

1.4 Frame parts list

No.	Part number	Pcs				
3	37473_Tubular beam	1		47	61180_Pin	2
4	37179_Drive end	1		48	37344_Pusher	1
5	10242_Cylinder	1		49	37007b_Slide fastener attaching plate (right)	1
7	37550_Hex screw M16	2		50	37510_Cylinder	1
8	96059_Washer DIN 125 A16	4		51	37007a_Slide fastener attaching plate	1
11	96061_Washer DIN 125 A8	42		53	37474_Chain oil tank assembly	1
12	96058_Washer DIN 125 A12	22		54	37149_Oil tank	1
13	96049_Washer DIN 125 A10	18		56	47671_Blade chain oil pump	1
14	96219_Lock nut DIN 985 M16	2		57	37600_Log press, complete	1
15	96211_Lock nut DIN 985 M14	6		59	95496_Splitting channel rubber 1X37	1
16	96222_Lock nut DIN 985 M8	8		60	37596_Rubber fastening lower plate	1
18	96068_Lock nut DIN 985 M10	12		61	37595_Rubber attaching plate	1
19	96195_Hexagonal nut DIN 934 M16	1		63	37607_Splitting blade guard	1
22	96139_Hex screw DIN 933 M10x25	7		65	37573_Belt guard	1
23	96161_Hex screw DIN 933 M8x20	16		67	96186_Lock screw DIN 603 M10x25	8
28	96149_Hex screw DIN 933 M12x45	3		68	96187_Lock screw DIN 603 M8x20	12
29	96165_Hex screw DIN 933 M8x30	6		72	97348_Filter box	1
32	96138_Hex screw DIN 933 M10x20	6		74	96253_Sesko washer M12	4
33	37467_Valve rack	1		76	96082_Washer DIN 440 M8	2
34	37319_In-feed conveyor	1		77	37013b_Pin 96	1
35	37298_Bed for the right angle gear	1		78	96240_Retaining ring DIN 472 35	1
36	95324_Right angle gear	1		79	96044_Retaining ring DIN 471 30	1
37	37345_Drive end protective mat	1		80	96042_Retaining ring DIN 471 25	5
38	37285_Sensor rack	1		83	96064_Washer DIN 9021 M10	6
39	37343_Plastic insert	1		85	96276_Lubrication nipple M8X1	3
44	60915_Splitting blade adjustment cylinder	1		86	96275_Lubrication nipple M8x1 90 GR	1
45	37347_Trigger of the splitting mechanism	1		98	37612_Sensor lug	1
46	10464_Release bushing	2		100	95536_Sensor	2
				101	96147_Hex screw DIN 933 M12x35	7
				102	95535_Sensor	1

1.5 Exploded view of frame 2

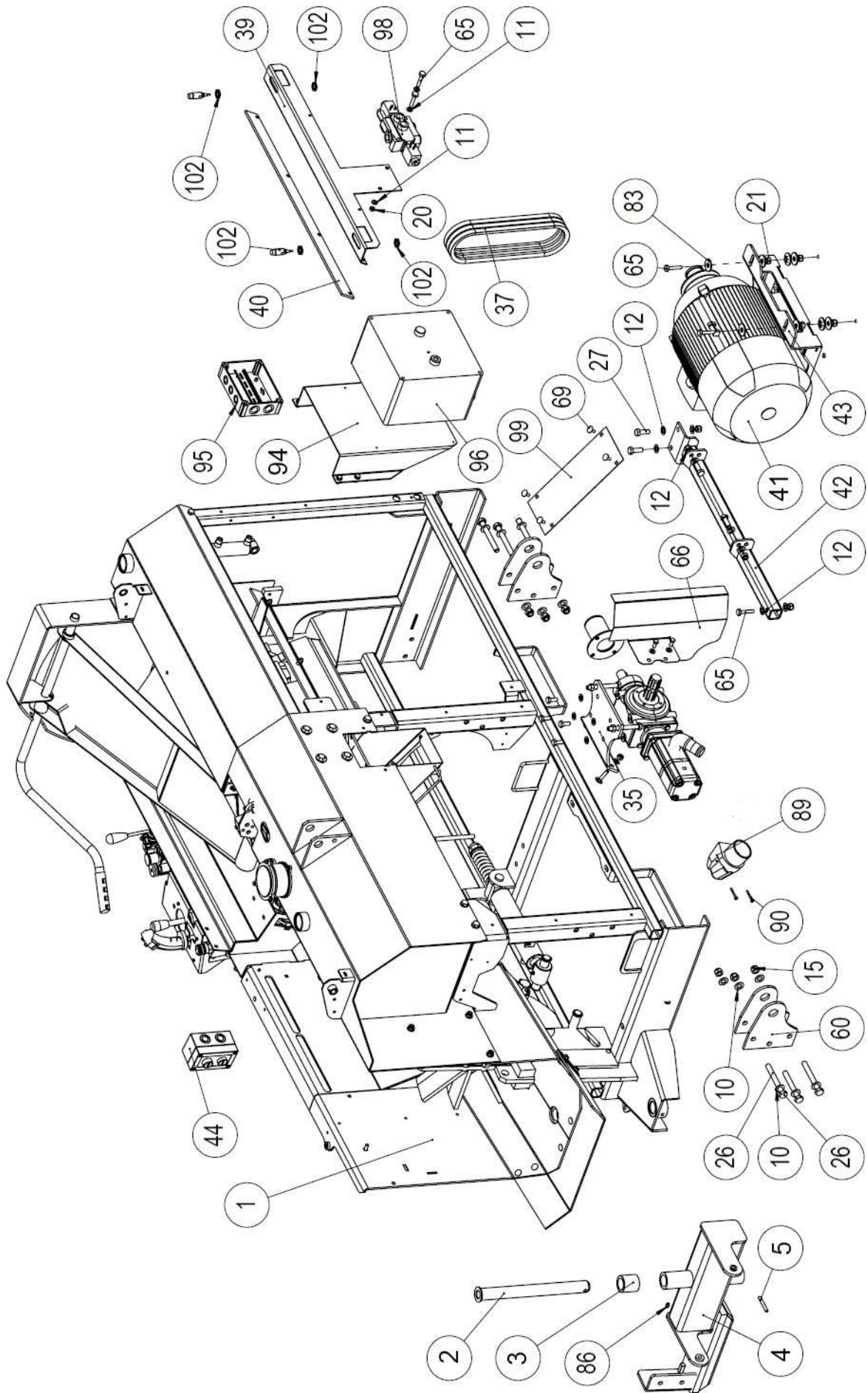

1.6 Frame 2 parts list

No.	Part number	Pcs
1	37380_Frame and splitting channel etc.	1
2	37507_Fastening pin of the turning device	1
3	38540_Bushing	1
4	10600_Conveyor turning device	1
5	96079_Spring pin DIN 481	1
10	96051_Washer DIN 125 A14	12
11	96061_Washer DIN 125 A8	47
12	96058_Washer DIN 125 A12	22
15	96211_Lock nut DIN 985 M14	6
20	96196_Hexagonal nut DIN 934 M8	20
21	96200_Hexagonal nut DIN 934 M12	12
26	96295_Hex screw DIN 933 M14x120	5
27	96147_Hex screw DIN 933 M12x35	5
35	37298_Bed for the right angle gear	1
37	95091_V-belt Li B35	3
39	37285_Sensor rack	1
40	37343_Plastic insert	1
	95421_Cage safety switch	1

41	95041_Electric motor 10 kW	1
42	37514_Electric motor mount	1
43	37291_Bed for the electric motor	1
44	95160_Remote starter	1
60	37454_Lifting arm lug	4
66	37573_Belt guard	1
65	?_Hex screw DIN 981 M10x45	8
69	96314_Lock screw DIN 603 M10x40	2
83	96340_Washer DIN 9021 M12	11
86	96276_Lubrication nipple M8X1	3
89	95163_32A Socket outlet	1
90	?_Slotted cheese head screw DIN 84 M5x40	2
94	97338_Attaching plate	1
95	95556_Relay box	1
95	95157_Starter 10 kW	1
97	37553_Fastener for the safety switch	1
98	50008910_Splitting valve kit	1
99	37580_Plate for the sawdust box	1
102	95536_Sensor	2

2.1 Exploded view and parts list of the lower section of the out-feed conveyor

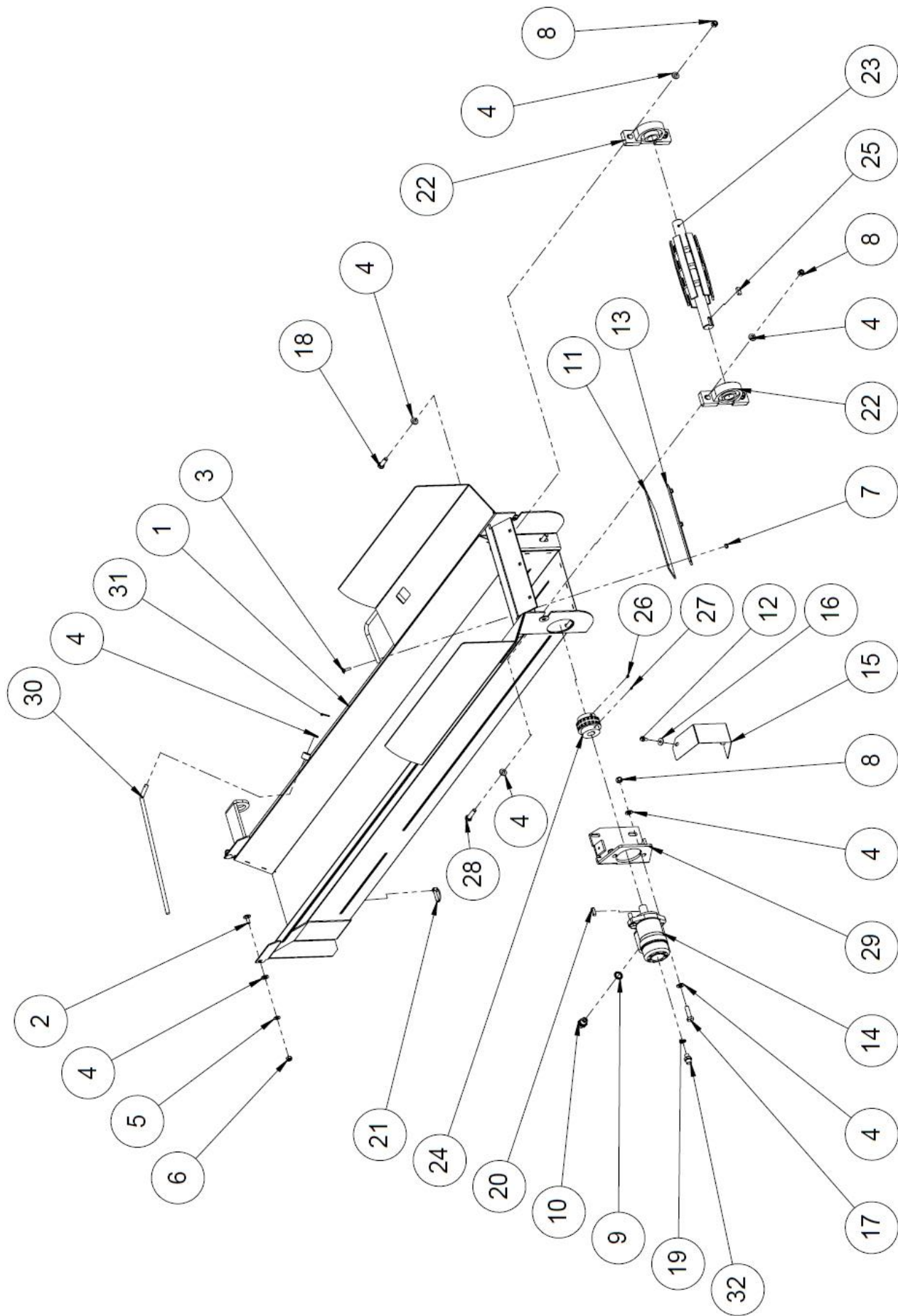

No.	Part number	Name	Dimensions	Pcs
1	50016683	Lower frame of the conveyor		1
2	96186	Lock screw	DIN 603 M10x25	2
3	96191	Lock screw	DIN 603 M8x25	3
4	96058	Washer	DIN 125 A12	15
5	96049	Washer	DIN 125 A10	2
6	96068	Lock nut	DIN 985 M10	2
7	96222	Lock nut	DIN 985 M8	3
8	96218	Lock nut	DIN 985 M12	6
9	97213	USIT seal	1/2"	2
10	97203	Double nipple	3/8", 1/2"	2
11	95130	Conveyor rubber flap		1
12	96172	Flange bolt	M8x16	2
13	61172	Conveyor rubber flap fastening rod		1
14	97334	Hydraulic motor	OMP-50	1
15	47654	Guard		1
16	96085	Washer	DIN 9021 M8	2
17	96149	Hex screw	DIN 933 M12x45	2
18	96148	Hex screw	DIN 933 M12x40	2
19	97211	USIT seal	1/4"	1
20	97371	Wedge		1
21	96242	Ring pin	8 mm	1
22	95058	Bearing unit UCP 207		2
23	50015676	Drive roller		1
24	95448	Chain coupling		1
25	47642	Wedge		1
26	96228	Socket set screw	DIN 916 M8x8	2
27	96362	Socket set screw	DIN 916 M6x8	2
28	96108	Hex screw	DIN 931 M12x50	2
29	50015466	Motor fastening plate		1
30	10819	Belt support		1
31	96246	Cotter pin	DIN 94 3.2x32	1
32	97201	Double nipple	1/4", 3/8"	1

2.2 Exploded view and parts list of the upper section of the out-feed conveyor (37400)

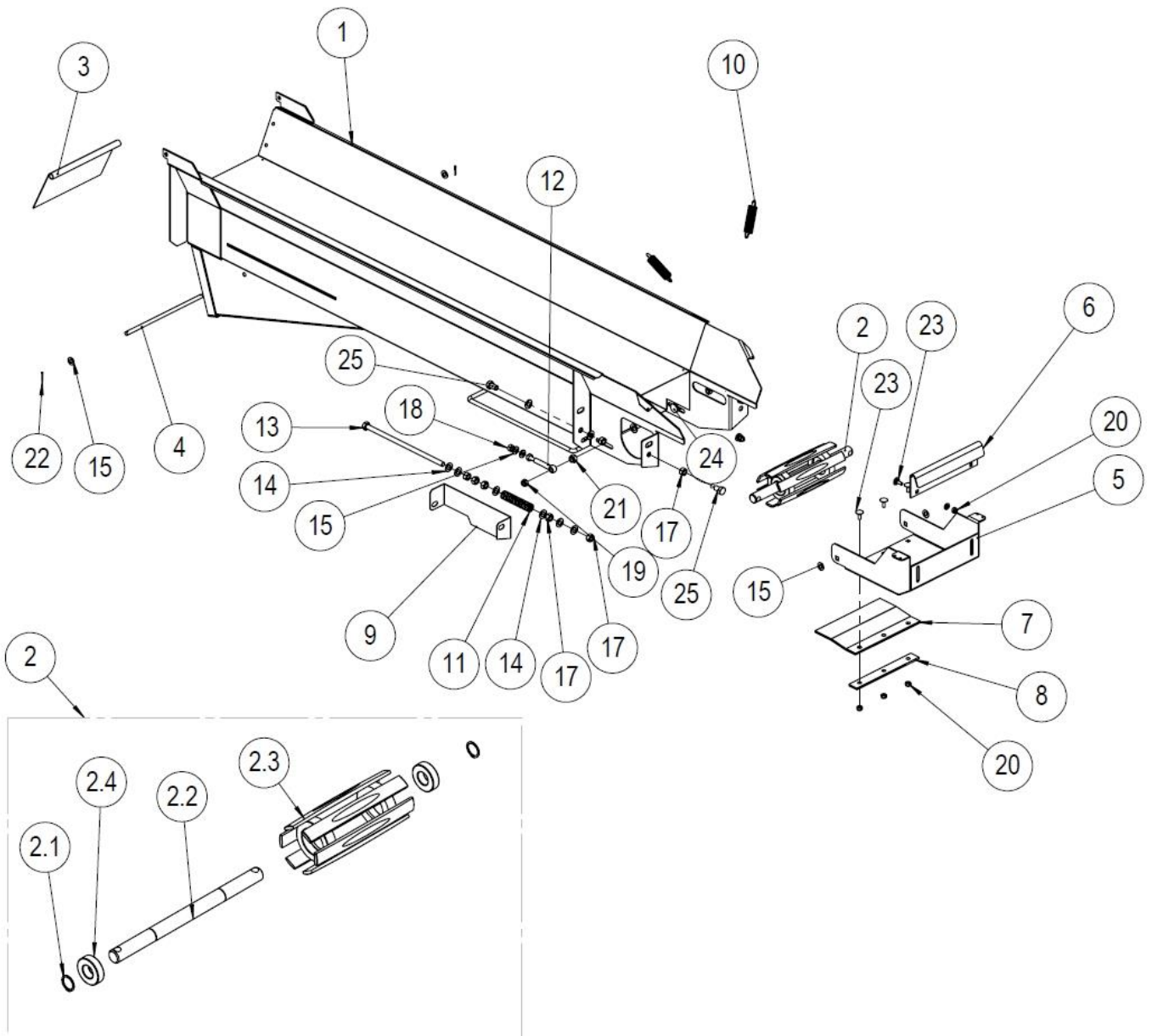

No.	Part number_Name	Pcs
1	10832_Frame of the upper part	1
2	10132_Conveyor upper roller	1
2.1	96042_Retaining ring DIN 471 25	2
2.2	10132b_Shaft for the conveyor upper roller	1
2.3	10142_Conveyor upper roller	1
2.4	95050_Bearing 6205 2 rs	2
3	37414_Debris opening guard plate	1
4	37411_Link rod	1
5	10834_Debris separator	1
6	37412_Lip plate	1
7	10864_Debris separator rubber	1
8	10136_Belt connection plate	1
9	10858_Protective plate for the roller	1
10	95390_Draw spring 2x20x100, yellow-passivated	2

11	95543_Pressure spring d4 D22 L100	2
12	96338_M10x90 Eye bolt DIN 444	2
13	96355_Hex screw 933 M12x280	2
14	96058_Washer DIN 125 A12	17
15	96049_Washer DIN 125 A10	8
16	96061_Washer DIN 125 A8	2
17	96200_Hexagonal nut DIN 934 M12	12
18	96199_Hexagonal nut DIN 934 M10	4
19	96068_Lock nut DIN 985 M10	2
20	96222_Lock nut DIN 985 M8	5
21	96218_Lock nut DIN 985 M12	2
22	96244_Cotter pin DIN 94 96244_2.5x20	2
23	96187_Lock screw DIN 603 M8x20	5
24	96312_Lock screw DIN 603 M10x50	2
25	96144_Hex screw DIN 933 M12x20	2

2.3 Exploded view and parts list of the out-feed conveyor (50016828)

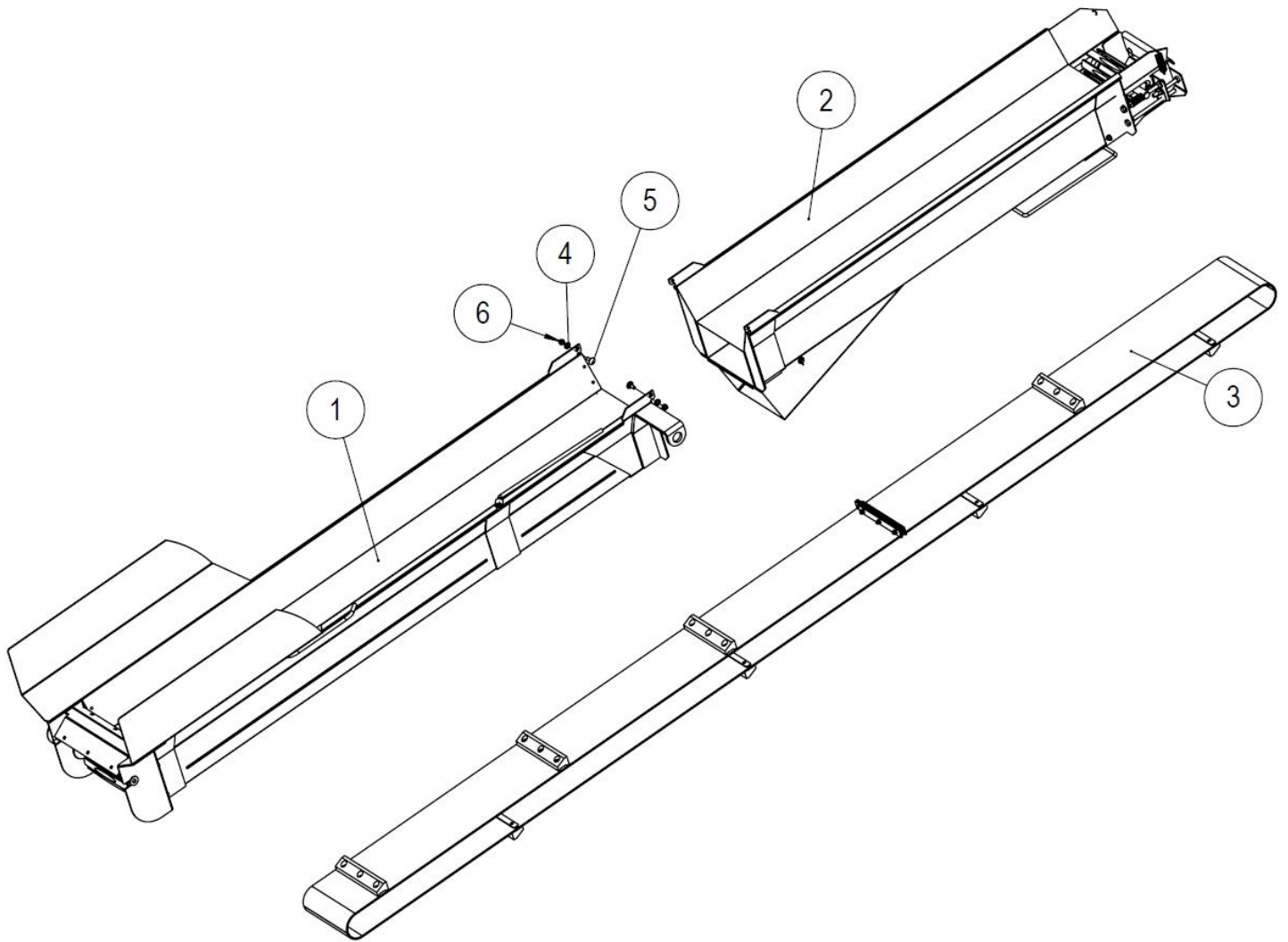

No.	Part number_Name	Pcs
1	50016683_Conveyor bottom	1
2	37400_Conveyor upper part with debris discharge	1
3	10317_Conveyor belt, complete	1
4	96049_Washer DIN 125 A10	2
5	96186_Lock screw DIN 603 M10x25	2
6	96068_Lock nut DIN 985 M10	2

2.4 Exploded view and parts list of the belt of the out-feed conveyor (10317)

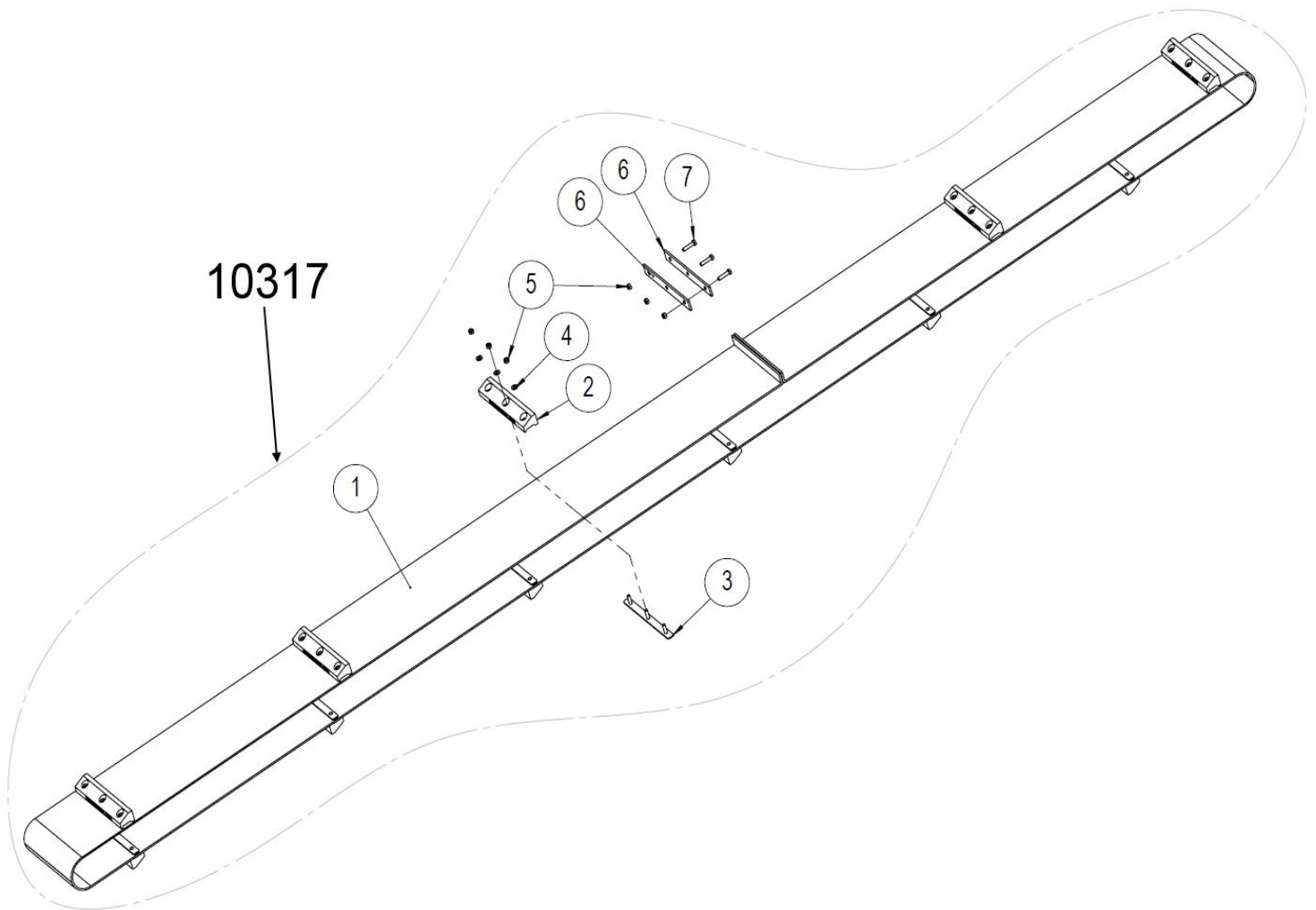

No.	Part number_Name	Pcs
1	95126_Conveyor belt 240EP 250.2+0 L=8130	1
2	96222_Lock nut DIN 985 M8	36
3	10851_Cleat fastening	11
4	95548_Plastic cleat	11
5	96061_Washer DIN 125 A8	33
6	10136_Belt connection plate	2
7	96166_Hex screw DIN 933 M8x35	3

3.1 Exploded view and parts list of the splitting valve kit (50008910)

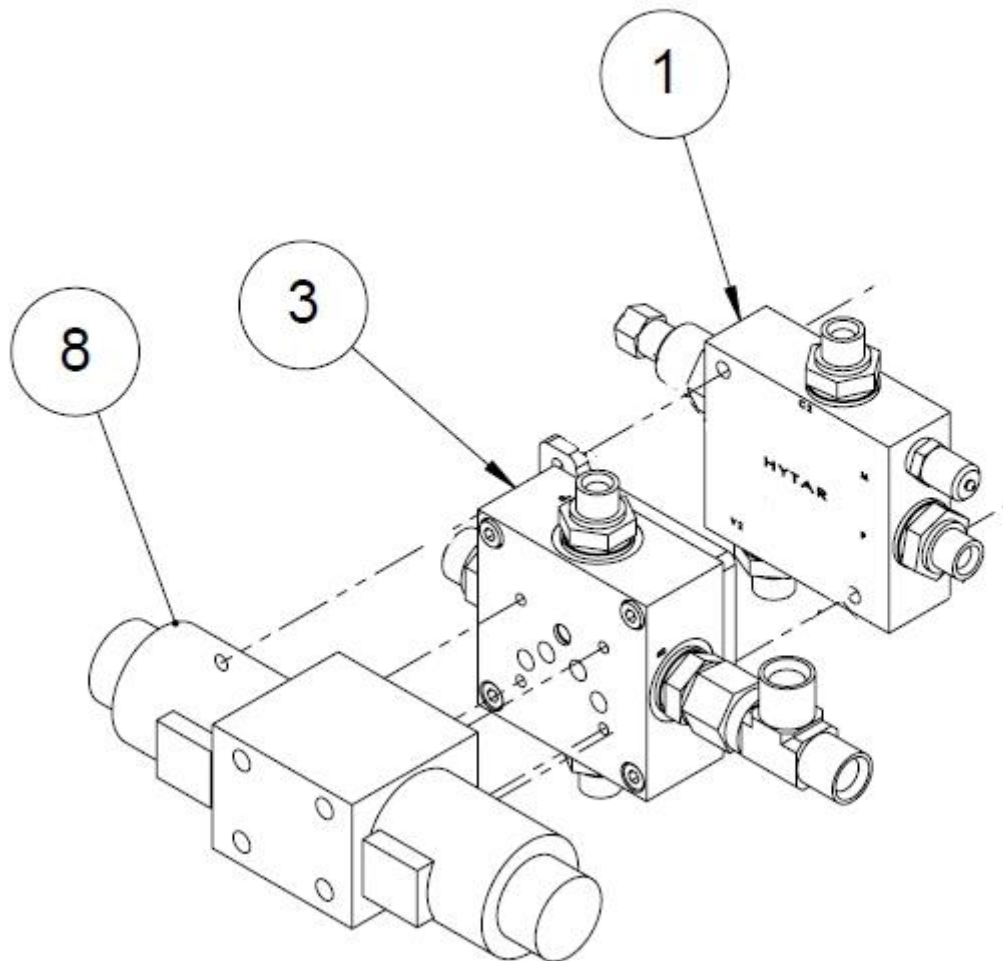

No.	Part number_Name	Pcs
1	50008381_Speed valve kit	1
3	50008382_Junction box kit	1
8	97841_Splitting valve, Cetop 5	1

3.2 Exploded view and parts list of the in-feed conveyor extension (37631)

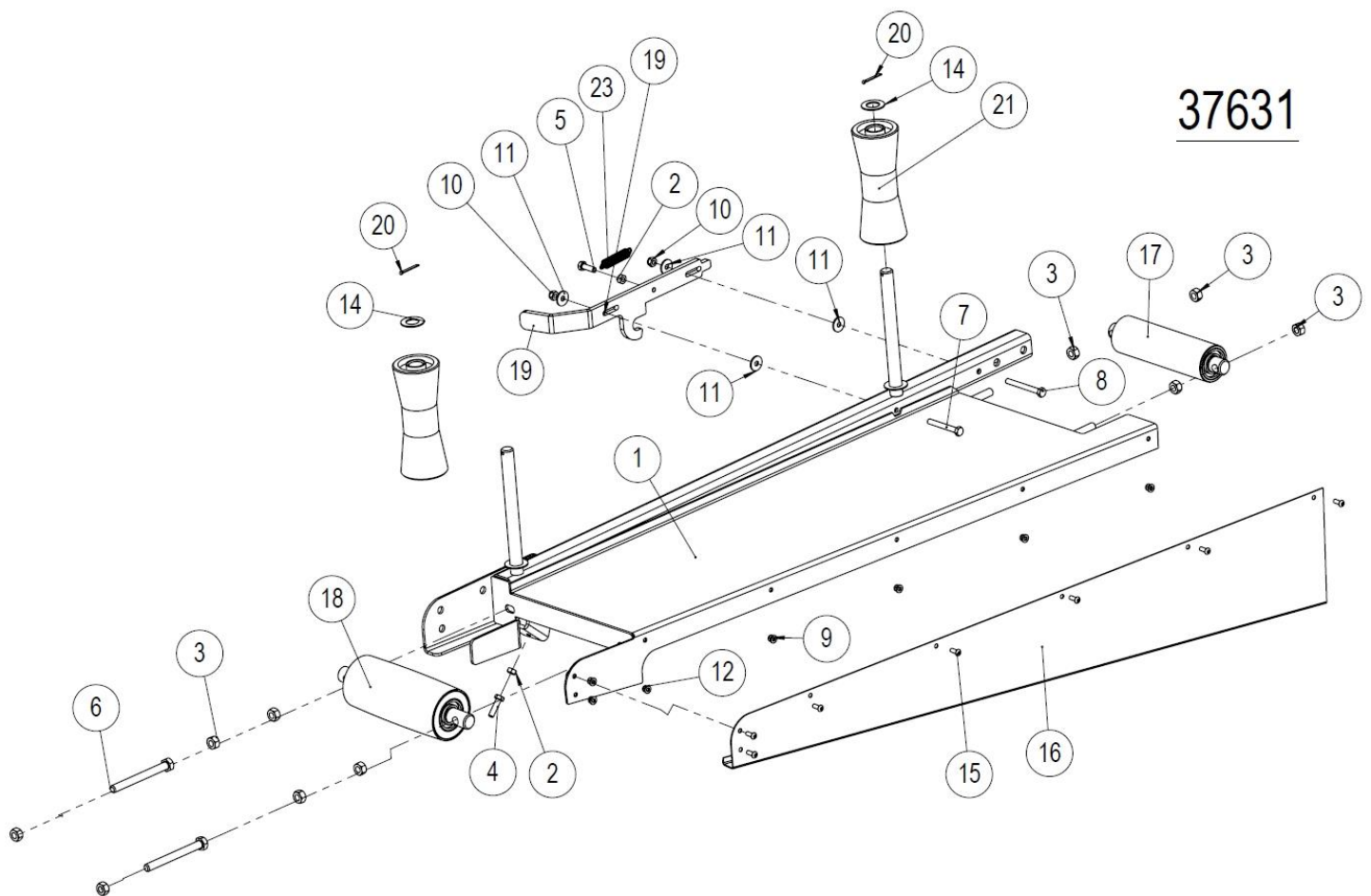

No.	Part number_Name	Pcs
1	37476_In-feed conveyor extension	1
2	96196_Hexagonal nut DIN 934 M8	2
3	96200_Hexagonal nut DIN 934 M12	10
4	96165_Hex screw DIN 933 M8x30	1
5	96164_Hex screw DIN 933 M8x25	1
6	96142_Hex screw DIN 933 M12x120	2
7	96127_Hex screw DIN 931 M8x65	1
8	96128_Hex screw DIN 931 M8x75	1
9	96221_Lock nut DIN 985 M6	7
10	96222_Lock nut DIN 985 M8	3
11	?_Nylon washer	4

12	96060_Washer DIN 125 A6	7
13	96061_Washer DIN 125 A8	1
14	96053_Washer DIN 125 A20	2
15	96004_Hex socket screw ISO 7380 M6x16	7
16	37584_Widening extension for the table extension	1
17	37528_Carryover roller	1
18	37524_Tensioning roller	1
19	37535_Lock	1
20	96246_Cotter pin DIN 94 3.2x32	2
21	95001_Keel roller	2
23	95423_Draw spring Ø2x15 L=75	1

3.3 Exploded view and parts list of the in-feed conveyor (37319)

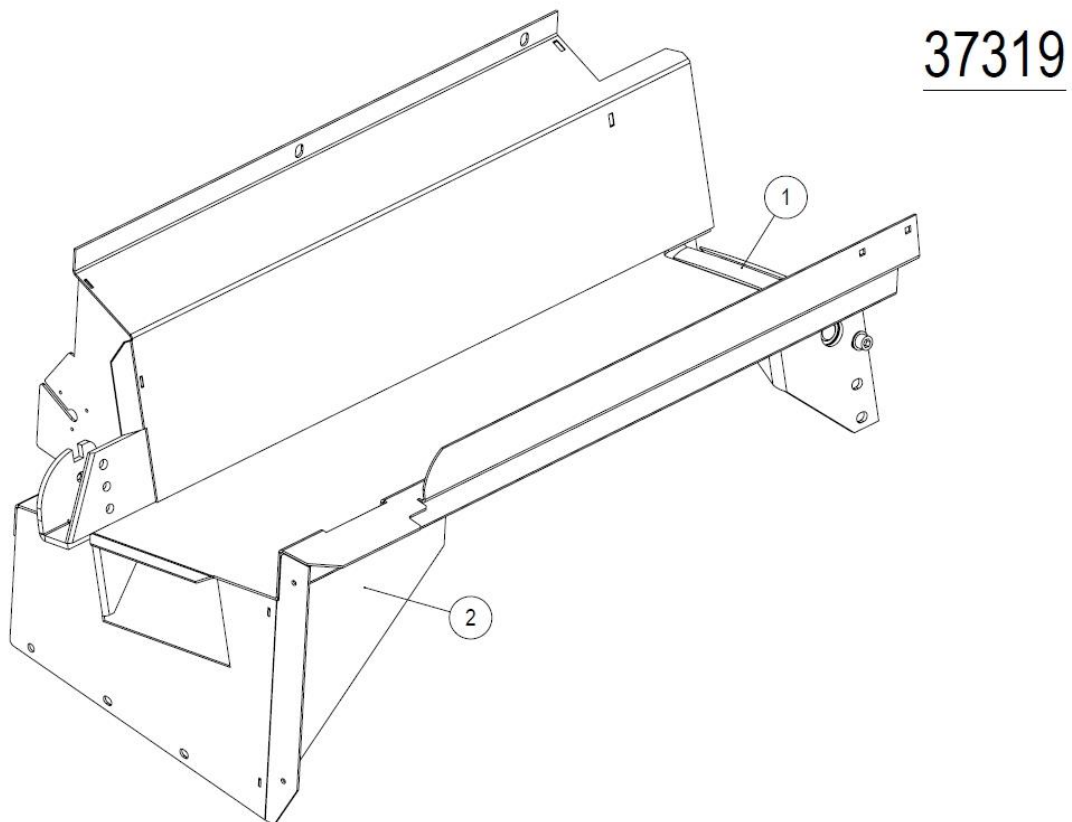

No.	Part number_Name	Pcs
1	37282_Drive roller assembly	1
2	37319_In-feed conveyor	1

3.4 Exploded view and parts list of the tensioning roller of the in-feed conveyor (37524)

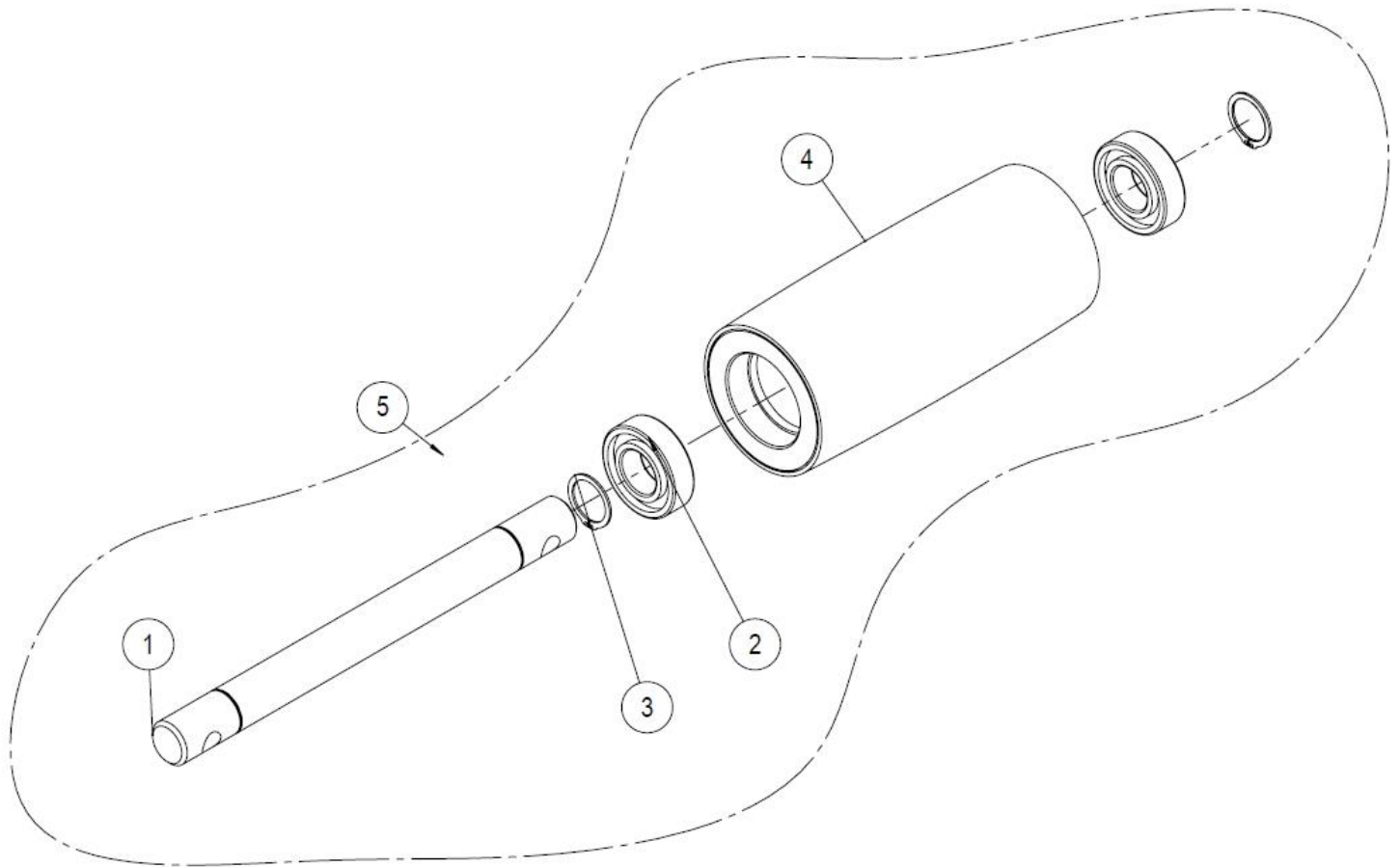

No.	Part number_Name	Pcs
1	37529_Tensioning roller shaft	1
2	95050_Bearing SKF- 6205	2
3	96042_Retaining ring DIN 471_25	2
4	37509_Tensioning roller	1
5	37524_Tensioning roller	1

**3.5 Exploded view and parts list of the middle roller of the in-feed conveyor
(37528)**

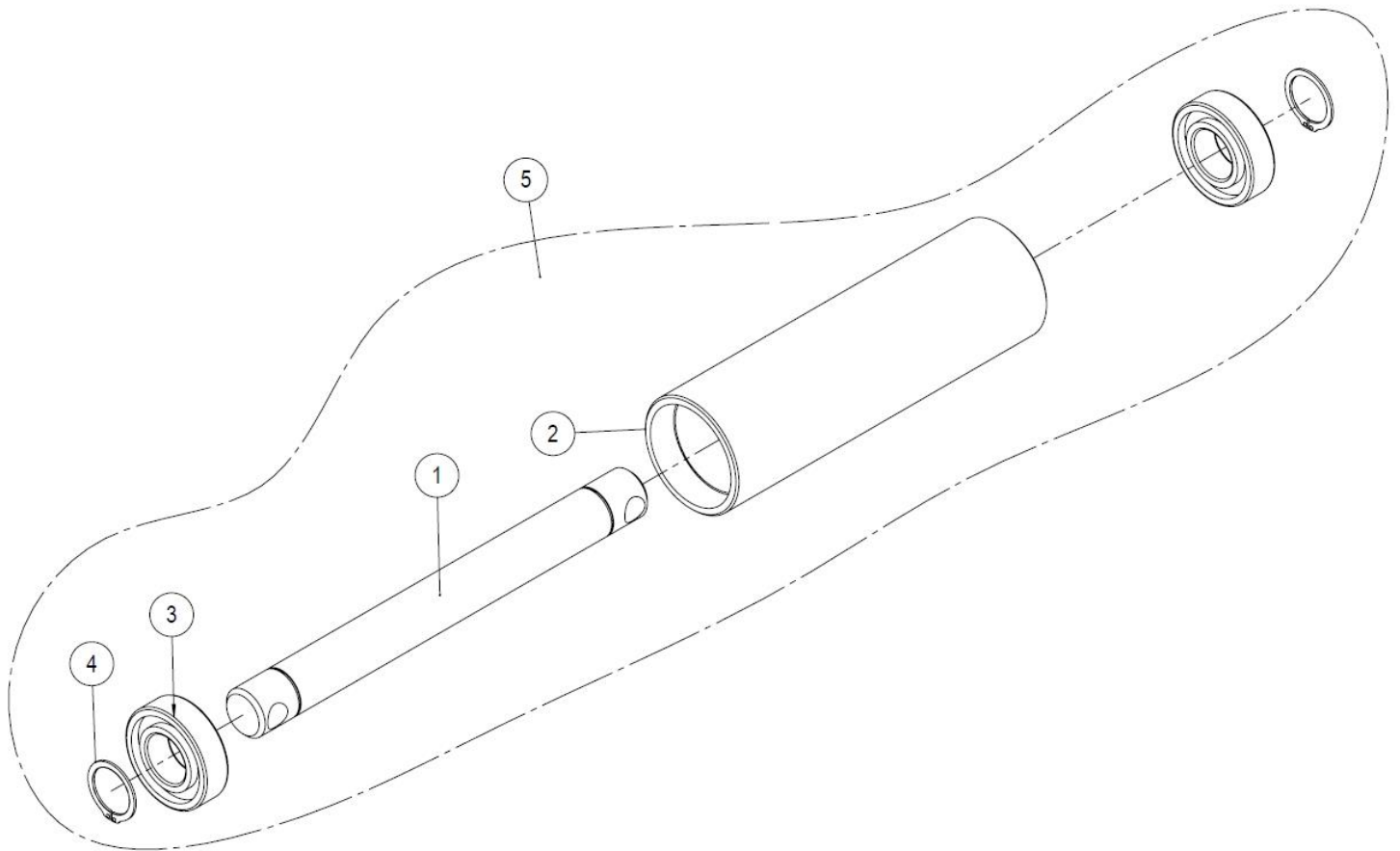

No.	Part number_Name	Pcs
1	10160b_Carryover roll shaft	1
2	37527_Carryover roll pipe	1
3	95050_Bearing SKF- 6205	2
4	96042_Retaining ring DIN 471_25	2
5	37528_Carryover roll	1

3.6 Exploded view and parts list of the pincher roll of the in-feed conveyor

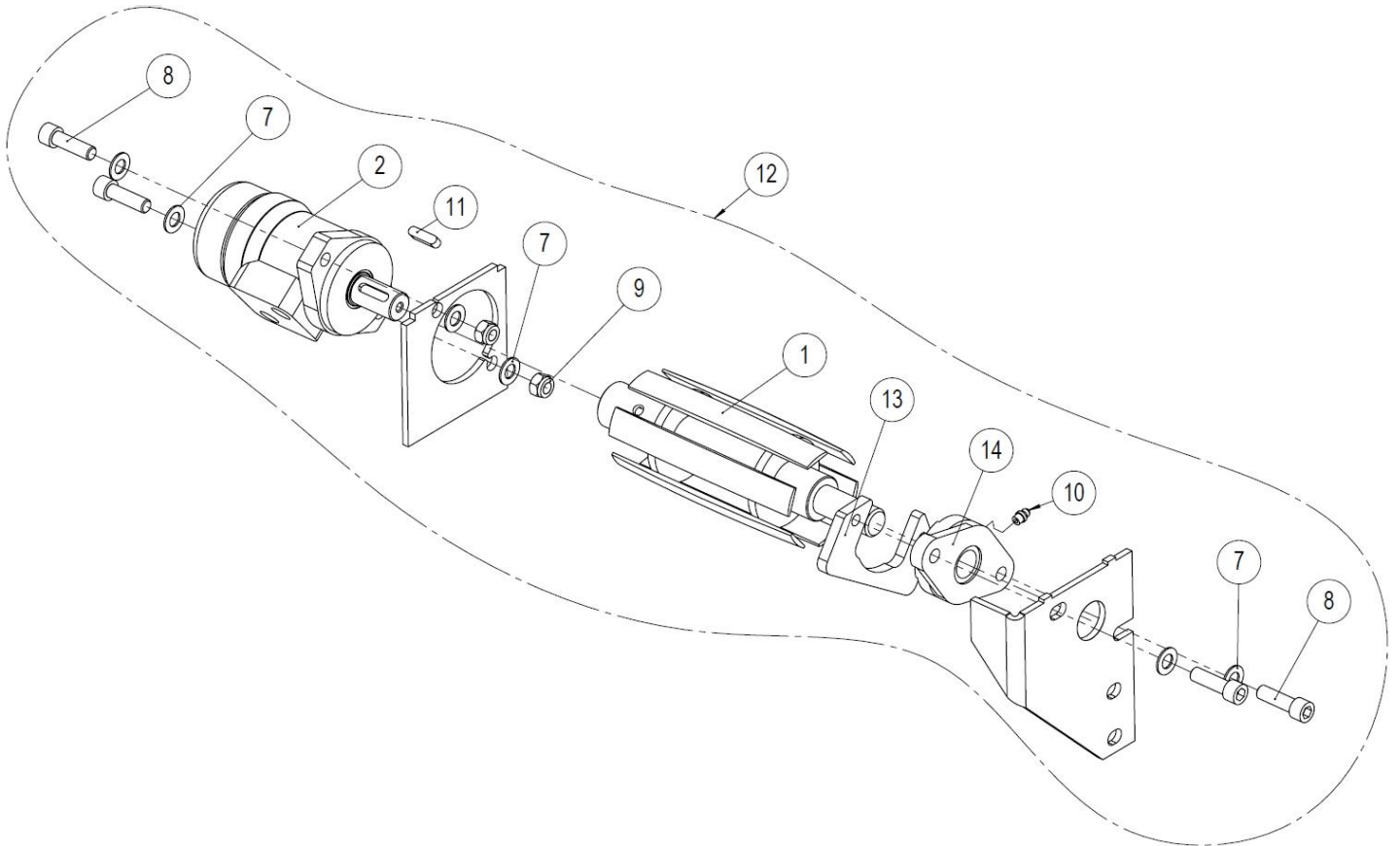

No.	Part number_Name	Pcs
1	10158_In-feed conveyor pincher roll	1
2	97307_Hydraulic motor 160 cc	1
5	37335_Drive roller attaching plate	1
6	37368_Hydraulic motor attaching plate	1
7	96058_Washer DIN 125 A12	6
8	96027_Hex socket screw DIN 912 M12x40	4
9	96218_Lock nut DIN 985 M12	2
10	96276_Lubrication nipple M8X1	1
11	97371_Wedge for the hydraulic motor	1
12	37282_Pincher roll	1
13	47159b_Bearing attaching plate	1
14	95318_Bearing UC 205	1

3.7 Exploded view and parts list of the saw unit

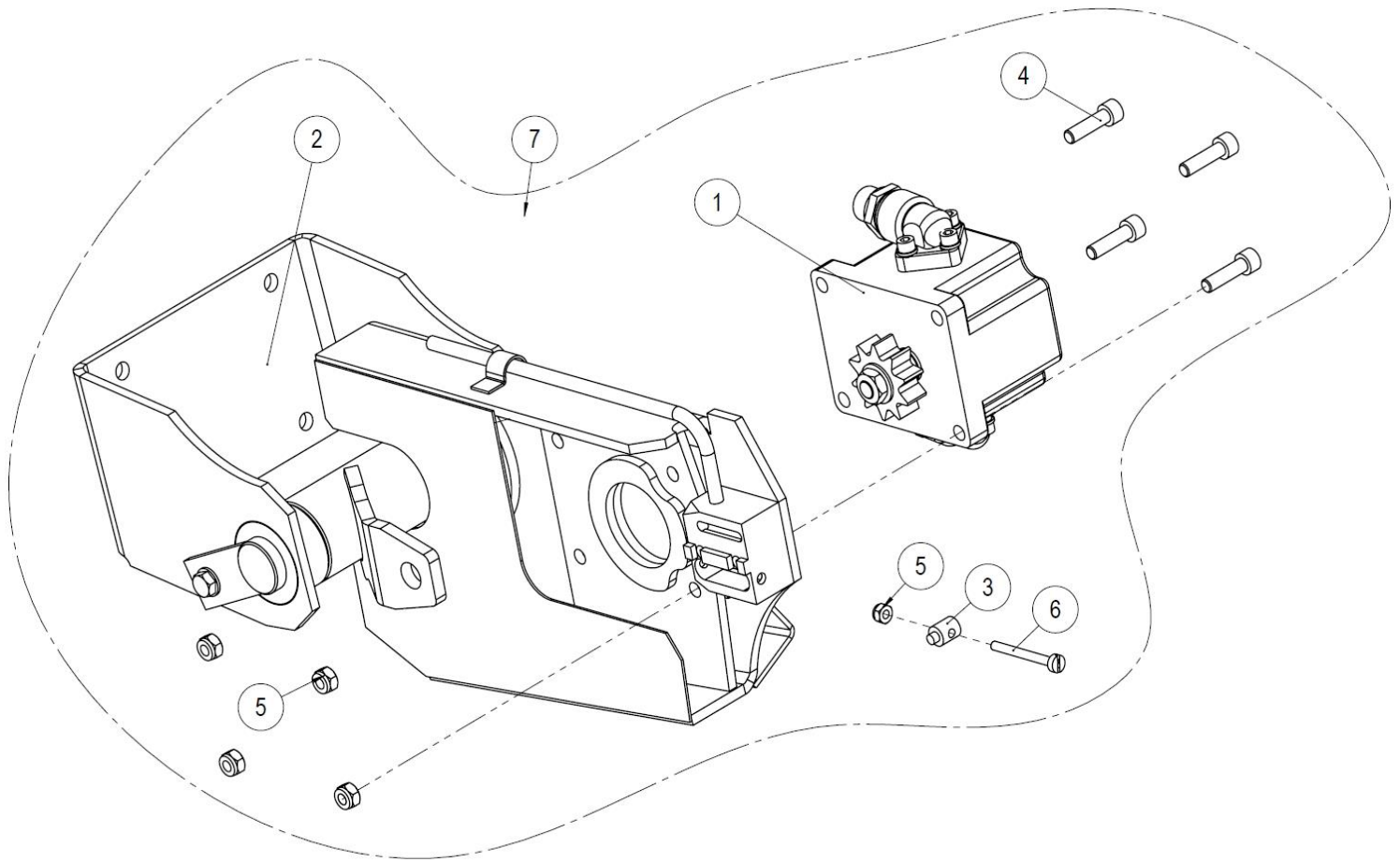

No.	Part number_Name	Pcs
1	37337_Gear motor and drive pulley	1
2	37628_Drive end assembly	1
3	10046_Flange tightening pin	1
4	96341_Hex socket screw DIN 912 M8x30	4
5	96221_Lock nut DIN 985 M6	5
6	96267_Slotted cheese head screw DIN 84 M6x70	1
7	37179_Saw unit assembly	1

3.8 Exploded view and parts list of the saw motor

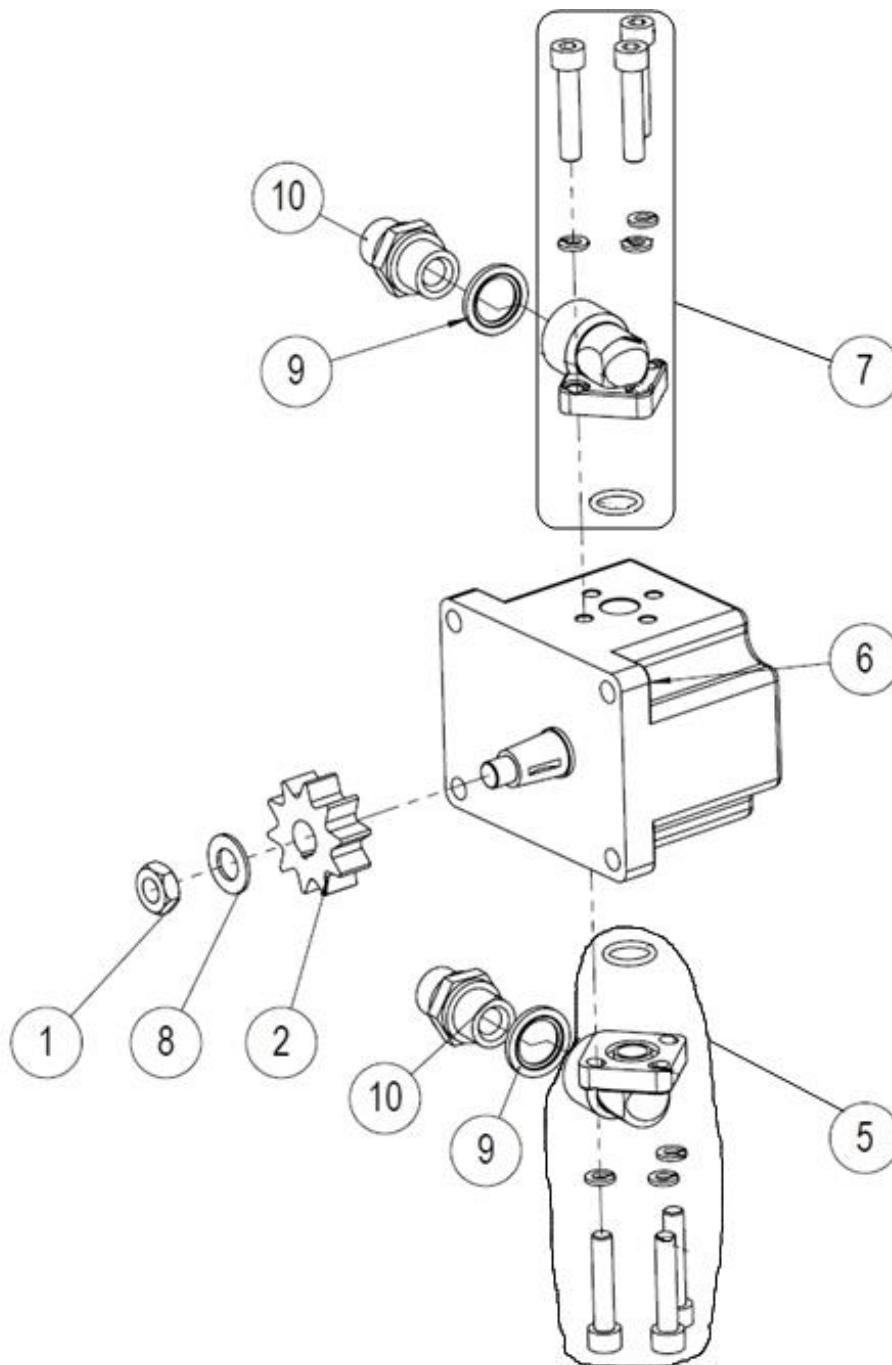

No.	Part number_Name	Pcs
1	96206_Hex nut DIN 936 M12	1
2	37336_Drive pulley 325-10	1
5	47850_Connection flange, complete	1
6	97572_Gear motor 6.3 DH	1
7	47851_Connection flange, complete	1
8	96058_Washer DIN 125 A12	1
9	97213_USIT 1.2	2
10	97204_Double nipple, straight	2

3.9 Exploded view and parts list of the saw drive end

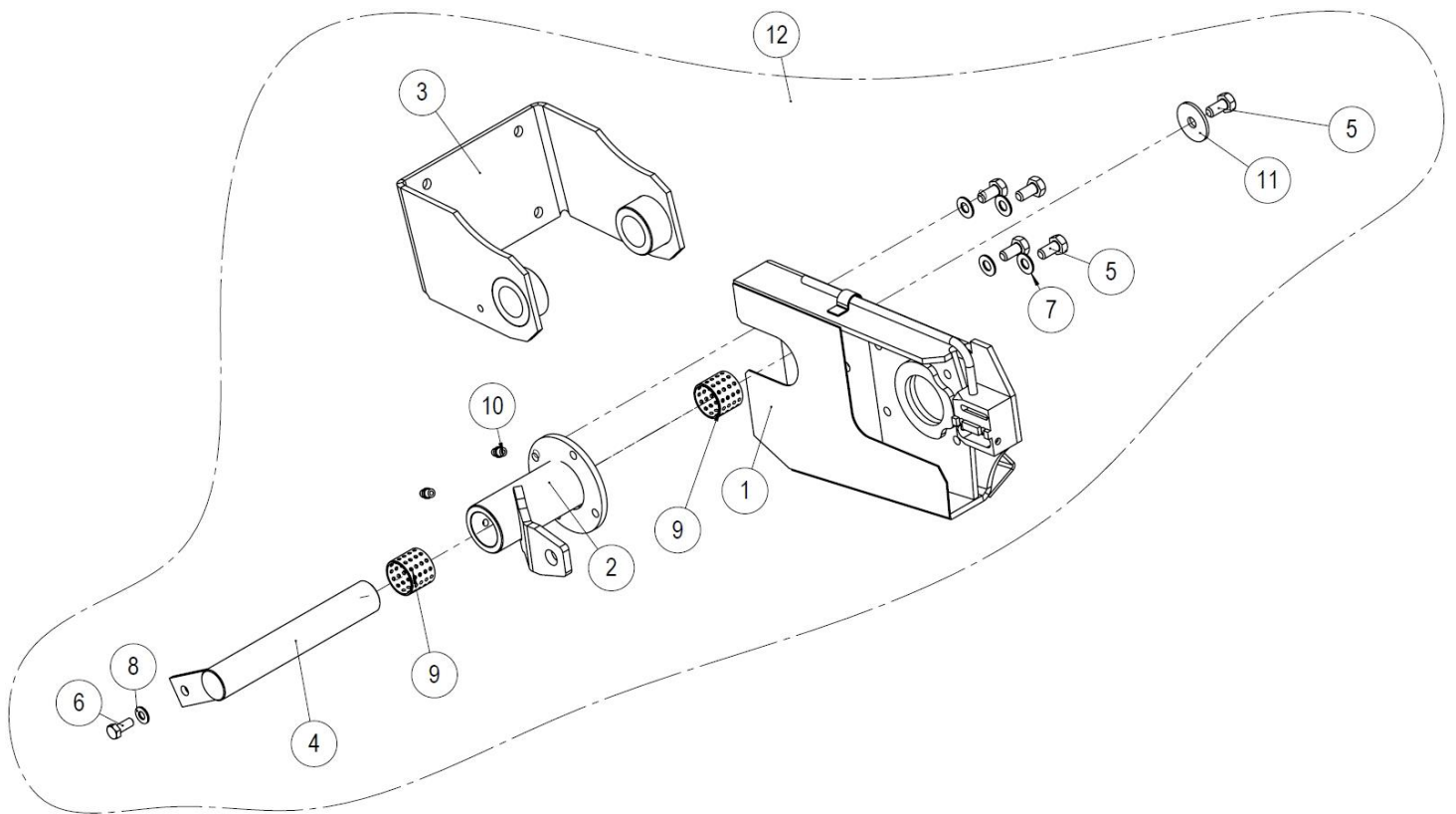

No.	Part number_Name	Pcs
1	37178_Drive end frame	1
2	37288_Drive end pipe	1
3	37296_Drive end attaching plate	1
4	47244_Drive end shaft	1
5	96138_Hex screw DIN 933 M10x20	5
6	96161_Hex screw DIN 933 M8x20	1
7	96049_Washer DIN 125 A10	4
8	96061_Washer DIN 125 A8	1
9	95276_Slide bearing	2
10	96276_Lubrication nipple M8X1	2
11	10492_Washer	1
12	37628_Drive end assembly	1

3.10 Exploded view and parts list of the saw unit cylinder (10242)

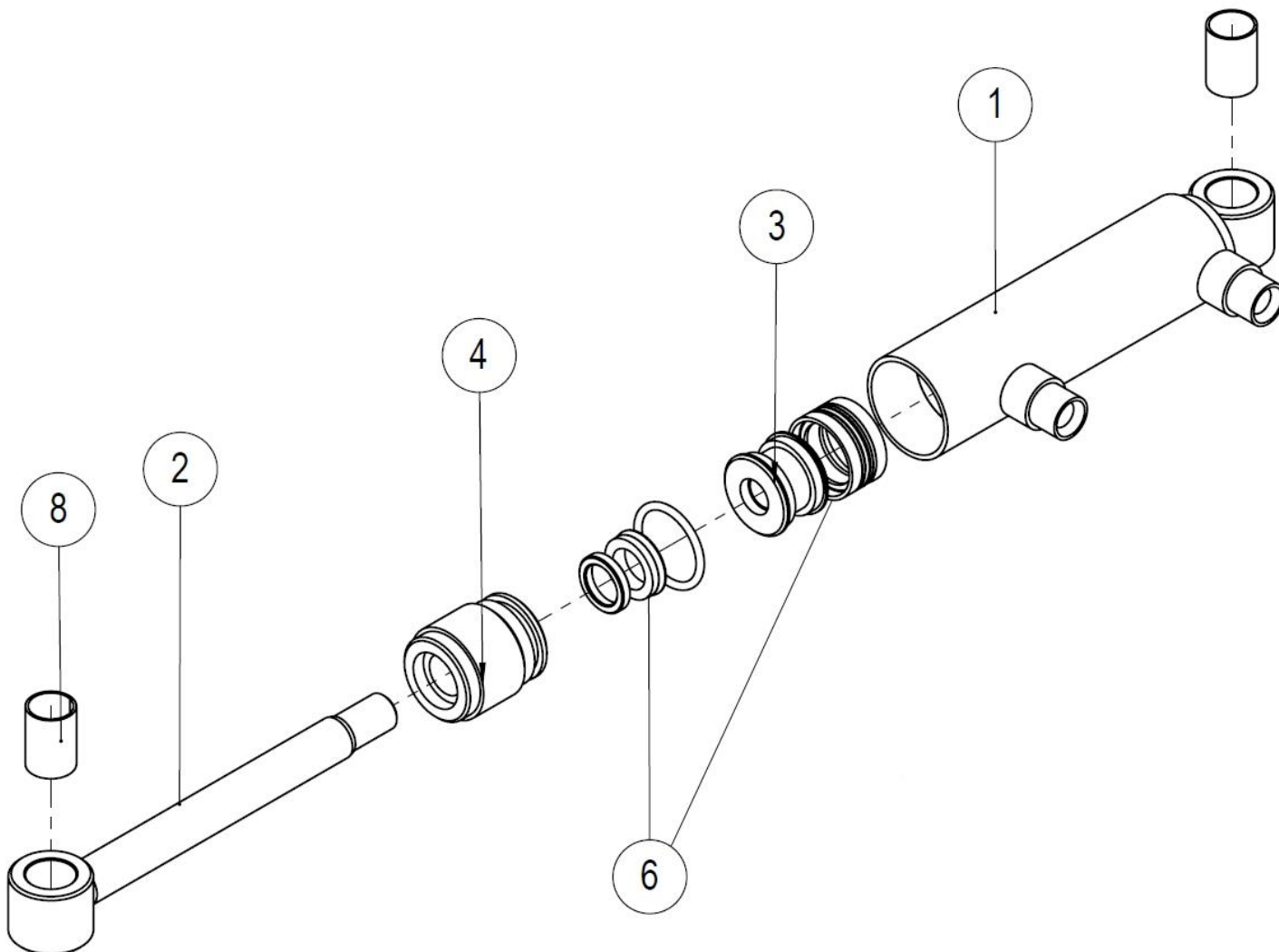

No.	Part number_Name	Pcs
1	47734_Cylinder pipe	1
2	47732_Cylinder rod	1
3	10270_Cylinder piston	1
4	10269_Cylinder rod control	1
8	95062_Slide bearing 18x16x25	2
6	97293_Cylinder seal kit 32/16	1

4.1 Exploded view and parts list of the control panel

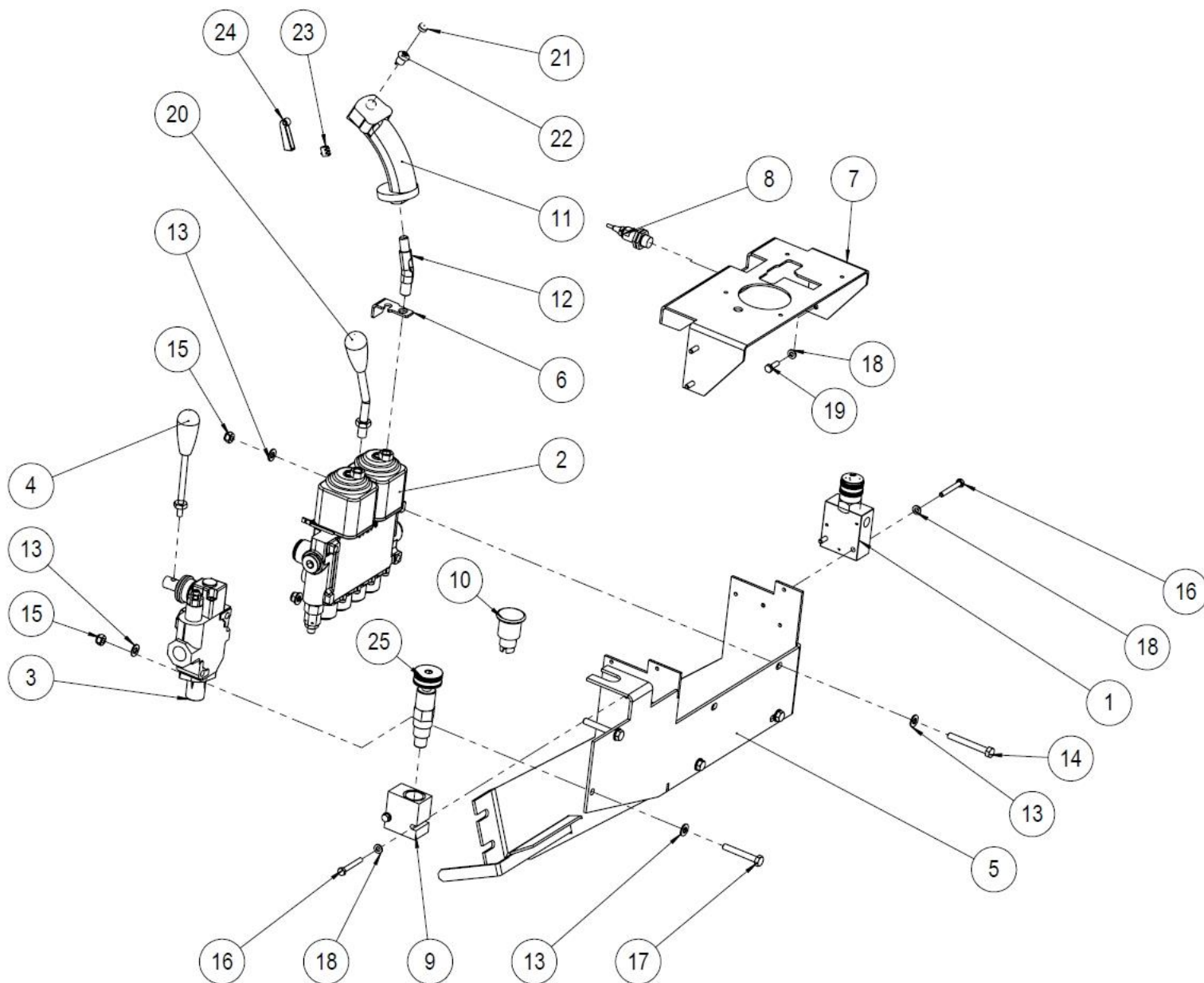

No.	Part number_Name	Pcs
1	97524_Volume control valve	1
2	97408_Hydraulic valve	1
3	97402_Valve	1
4	97423_AL01 M8 120 lever	1
5	37350_Control panel frame	1
6	37351_Sensor trigger	1
7	37363_Guide plate for the regulating valve	1
8	95535_Sensor	1
9	97420_Cartridge housing	1
10	95537_Reversing button A22-MB	1
11	37647_Joystick	1
12	47531f_Joystick attachment arm	1

13	96061_Washer DIN 125 A8	10
14	96127_Hex screw DIN 931 M8x65	3
15	96222_Locking nut DIN 985 M8	5
16	96336_Hex screw DIN 931 M6x45	4
17	96125_Hex screw DIN 931 M8x55	2
18	96060_Washer DIN 125 A6	8
19	96135_Hex screw DIN 933 M6x20	4
20	10753_Valve operating lever	1
21	97458_Red button	1
22	97600_Joystick button switch	1
23	97601_Trigger switch	1
24	97602_Trigger button	1
25	97427_Pressure control cartridge	1

5.1 Exploded view and parts list of the log press (37600)

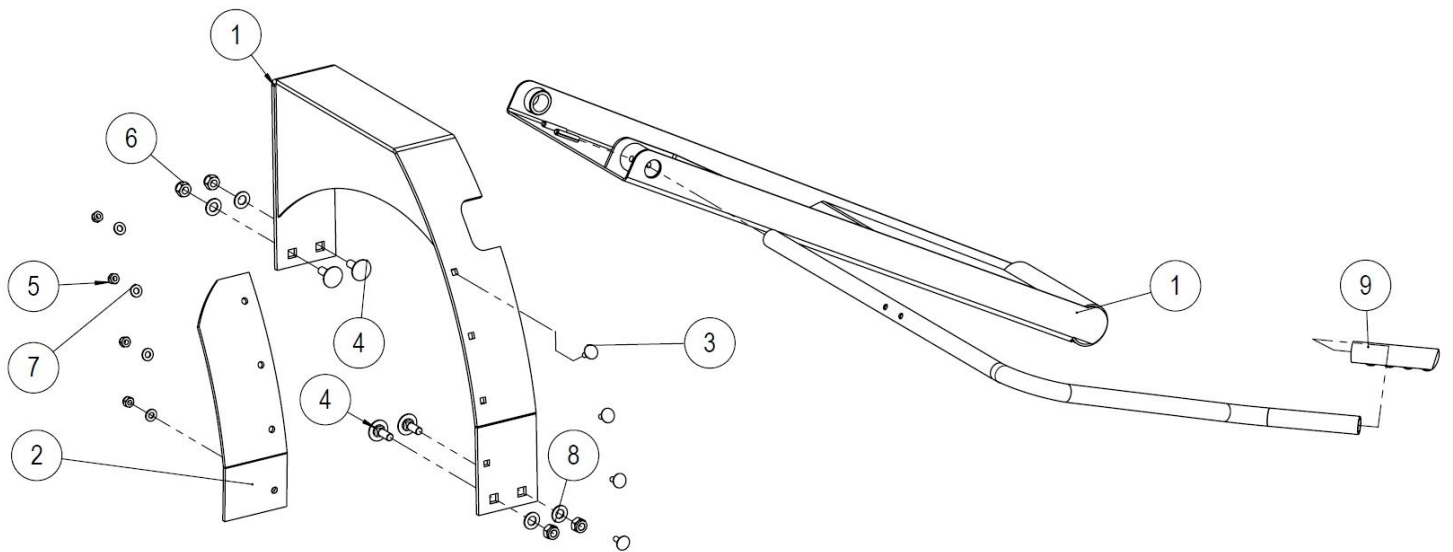

No.	Part number_Name	Pcs
1	37599_Attachment + log press	1
2	37572_Front edge rubber cover	1
3	96187_Lock screw DIN 603 M8x20	4
4	96188_Lock screw DIN 603 M12x30	4
5	96222_Lock nut DIN 985 M8	4
6	96218_Lock nut DIN 985 M12	4
7	96061_Washer DIN 125 A8	5
8	96058_Washer DIN 125 A12	4
9	95595_Handle	1
10	37600_Log press, complete	1

6.1 Exploded view and parts list of the mechanical measuring device

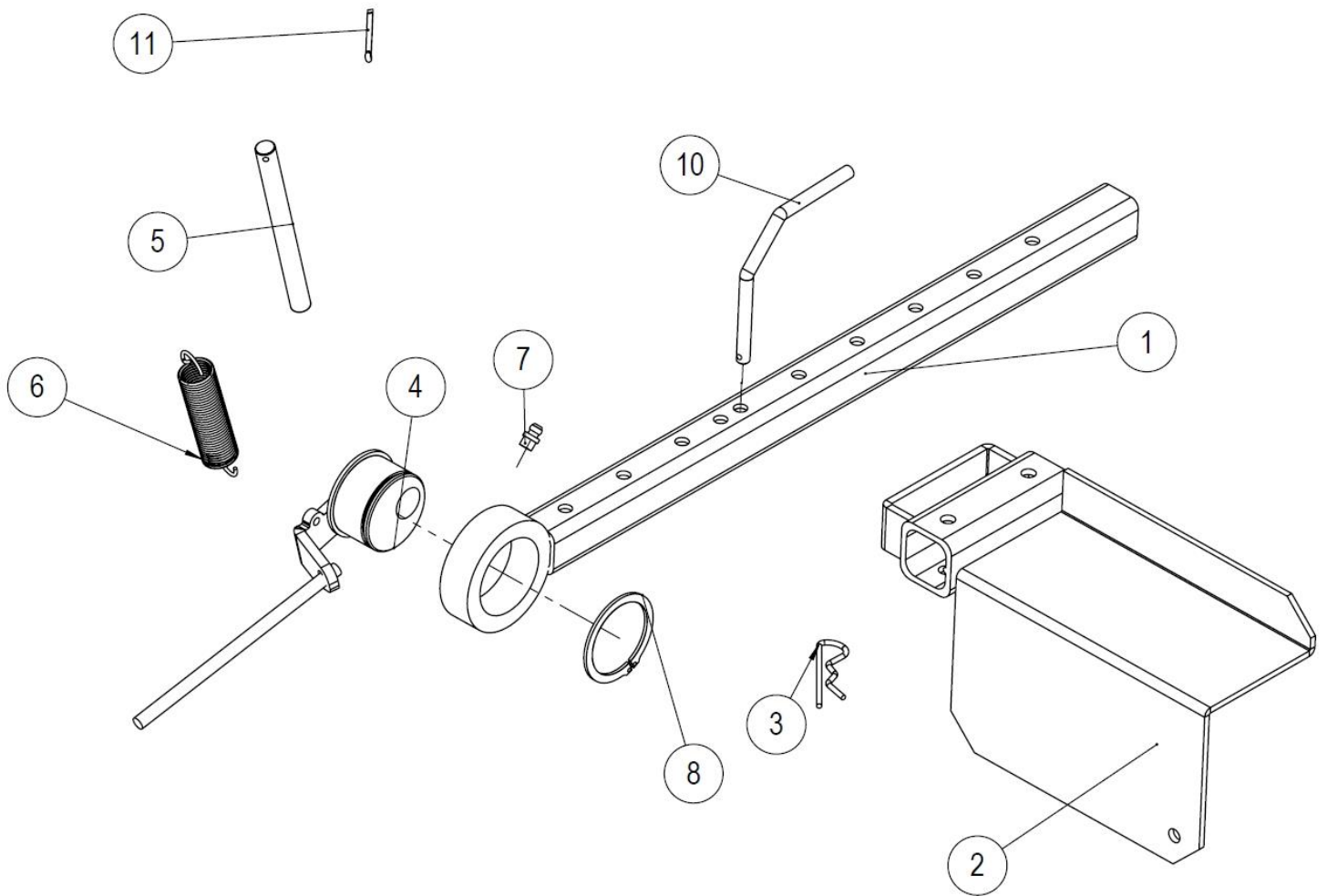

No.	Part number_Name	Pcs
1	10196_Log measuring device pipe	1
2	10063_Measuring device guard plate	1
3	96208_Needle pin	1
4	37562_Eccentric flange of the measuring device	1
5	37357_Stopper disc	1
6	95390_Draw spring 2x20x100	1
7	96276_Lubrication nipple M8X1	1
8	96046_Retaining ring DIN 471_50	1
10	10065_Locking pin	1
11	96246_Cotter pin DIN 94_3.2x32	1

6.2 Exploded view and parts list of the optical measuring device

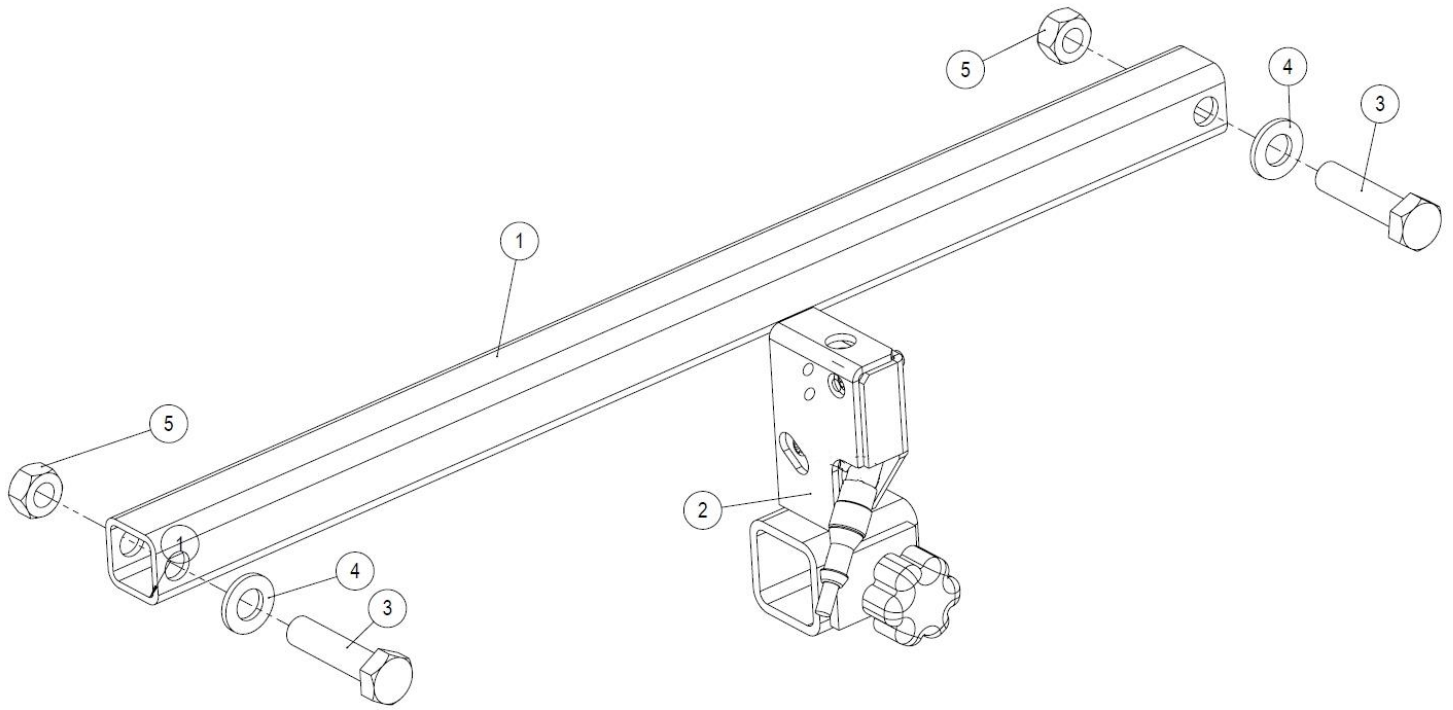

No.	Part number_Name	Pcs
1	60651_Tubular beam	1
2	47666_Optical measuring device with casing	1
3	96108_Hex screw DIN 931 M12x50	2
4	96058_Washer DIN 125 A12	2
5	96200_Hexagonal nut DIN 934 M12	2

6.3 Exploded view and parts list of the optical eye and casing

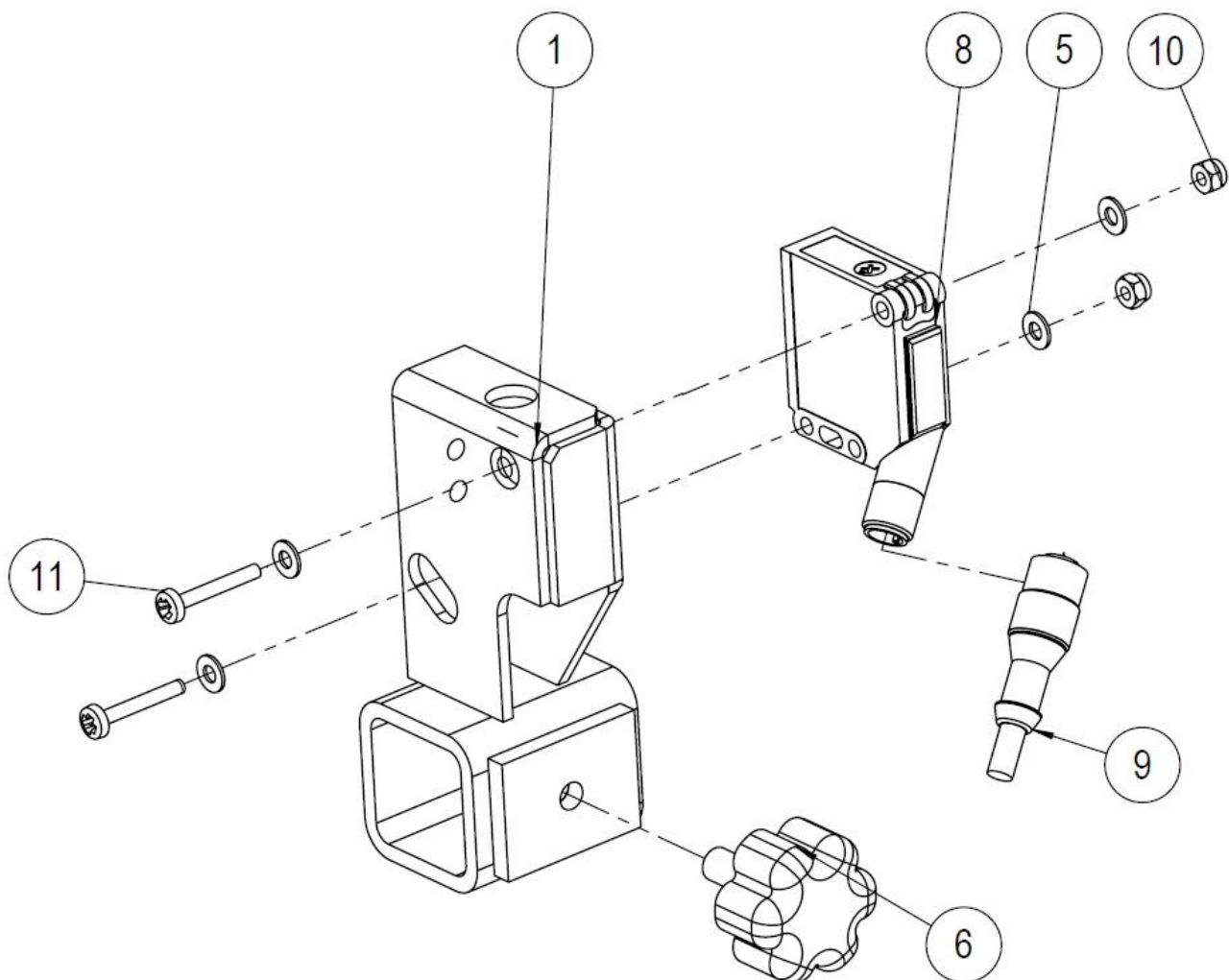

No.	Part number_Name	Pcs
1	47550_Log length measuring device	1
5	96313_Washer DIN 125 A4	4
6	95033_Knurled head screw M8-20	1
8	95549_Optical source	1
9	95554_Optical sensor cable DOL-1204-G05M	1
10	?_Locking nut DIN EN ISO 10511 M4	2
11	96261_Pan head screw DIN 7985 M4x25 -Z	2

7.1 Exploded view and parts list of the filter

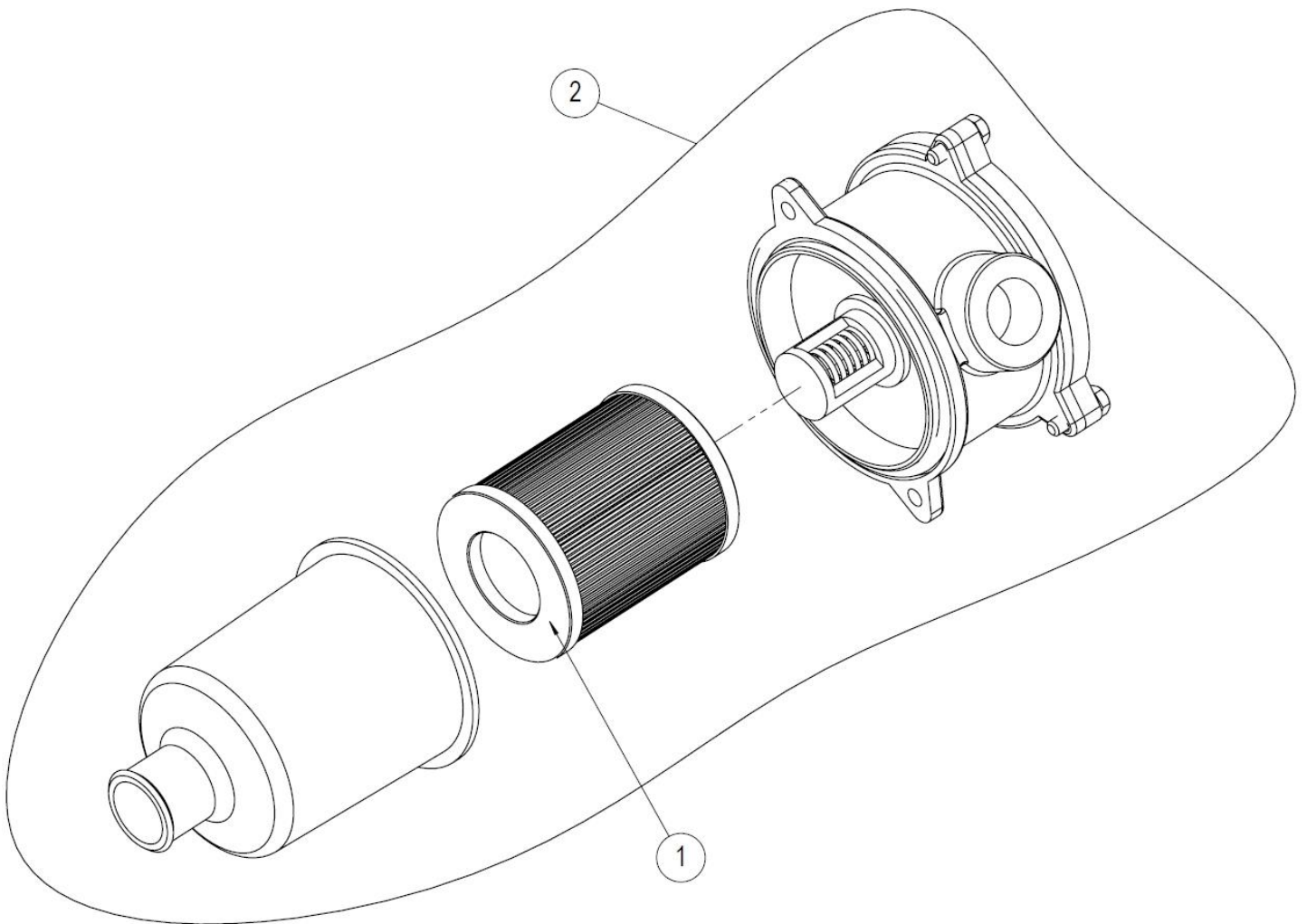

No.	Part number_Name	Pcs
1	97348_Filter insert	1
2	97349_Filter box, complete	1

8.1 Exploded view and parts list of the splitting blade guard

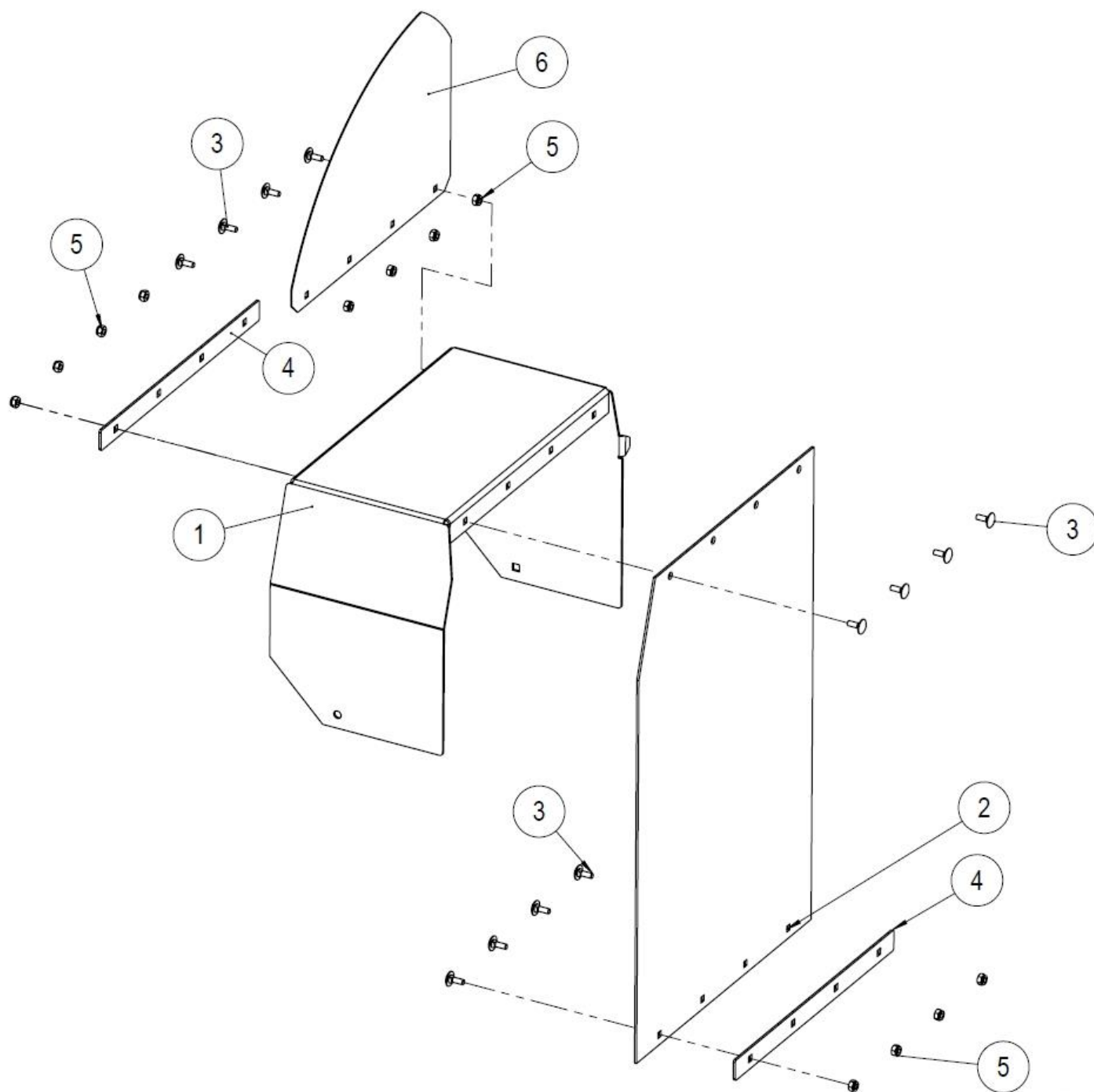

No.	Part number_Name	Pcs
1	37606_Splitting blade guard plate	1
2	37608_Protective mat	1
3	96187_Lock screw DIN 603 M8x20	12
4	37609_Attachment plate for the protective mat	2
5	96222_Lock nut DIN 985 M8	12
6	37614_Upper guard of the splitting mechanism	1
7	96061_Washer DIN 125 A8	4

9.1 Exploded view and parts list of the power transmission (the combi model, 37611)

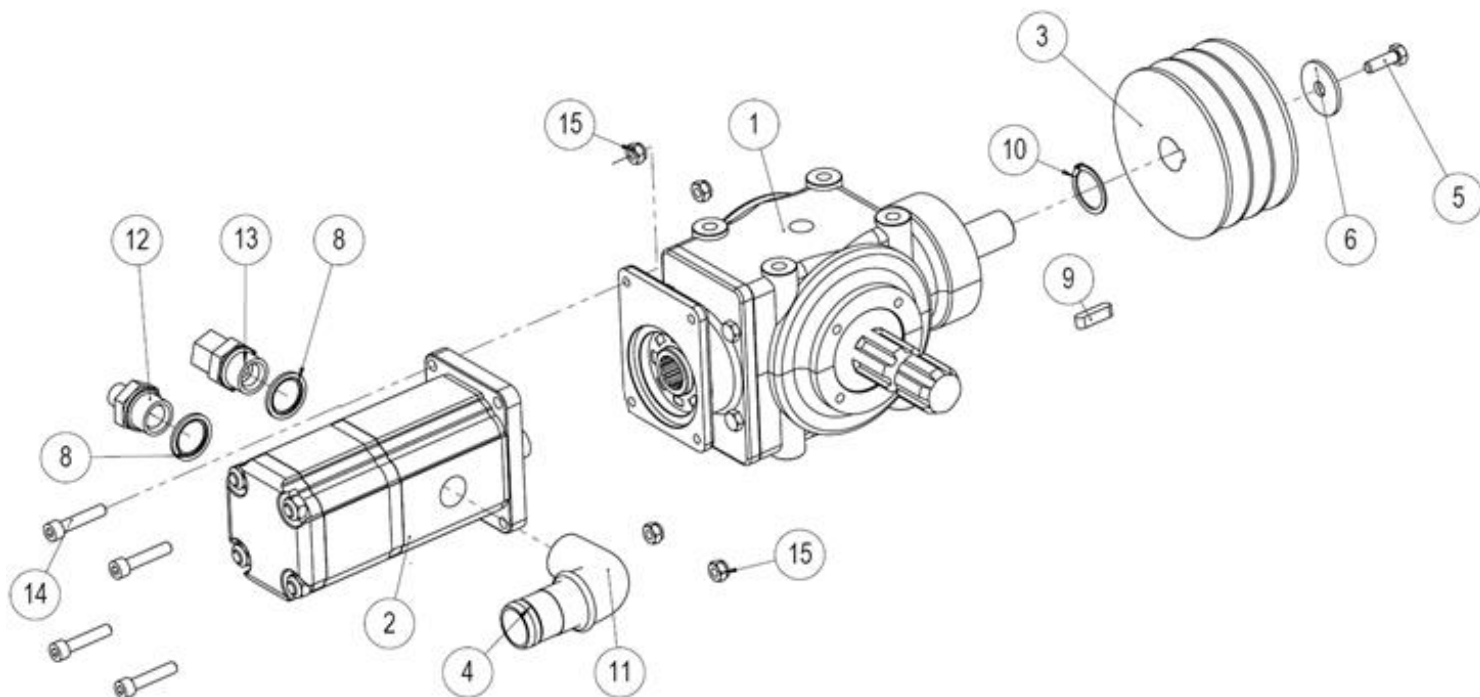

No.	Part number_Name	Pcs
1	95324_Right angle gear	1
2	97514_Pump	1
3	95528_Belt pulley B3, 125-25	1
4	47112_C_Nipple	1
5	96164_Hex screw DIN 933 M8x25	1
6	10492_Washer	1
7	97212_3.8 USIT	1
8	97214_USIT 3.4	2
9	97371_Hydraulic motor wedge	1
10	96044_Retaining ring DIN 471 30	1
11	95315_3.4 curve	1
12	97206_Double nipple straight 3/4 x 3/8	1
13	97217 Connecting nipple	1
14	96037_Hex socket screw DIN 912 M8x40	4
15	96222_Lock nut DIN 985 M8	4

9.2 Exploded view and parts list of the power transmission (the tr model, 37632)

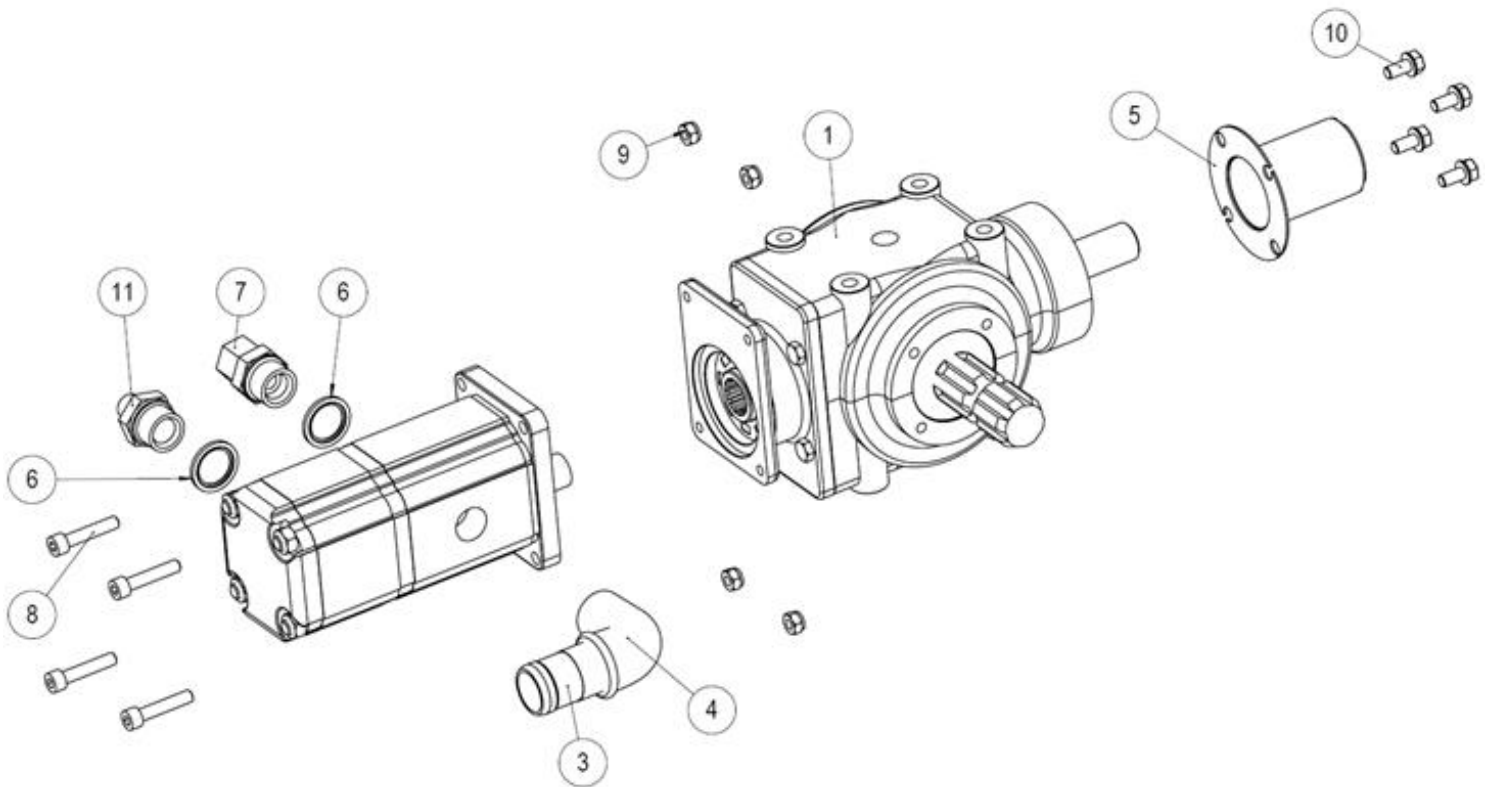

No.	Part number_Name	Pcs
1	95324_Right angle gear	1
2	97514_Pump	1
3	47112_C_Nipple	1
4	95315_3.4 curve	1
5	37622_Shaft guard	1
6	97214_USIT 3.4	2
7	97217_Connecting nipple	1
8	96037_Hex socket screw DIN 912 M8x40	4
9	96222_Lock nut DIN 985 M8	4
10	96172_Flange bolt M8x16	4
11	97206_Double nipple straight 3/4 x 3/8	1

9.3 Exploded view and parts list of the electric motor (Combi model)

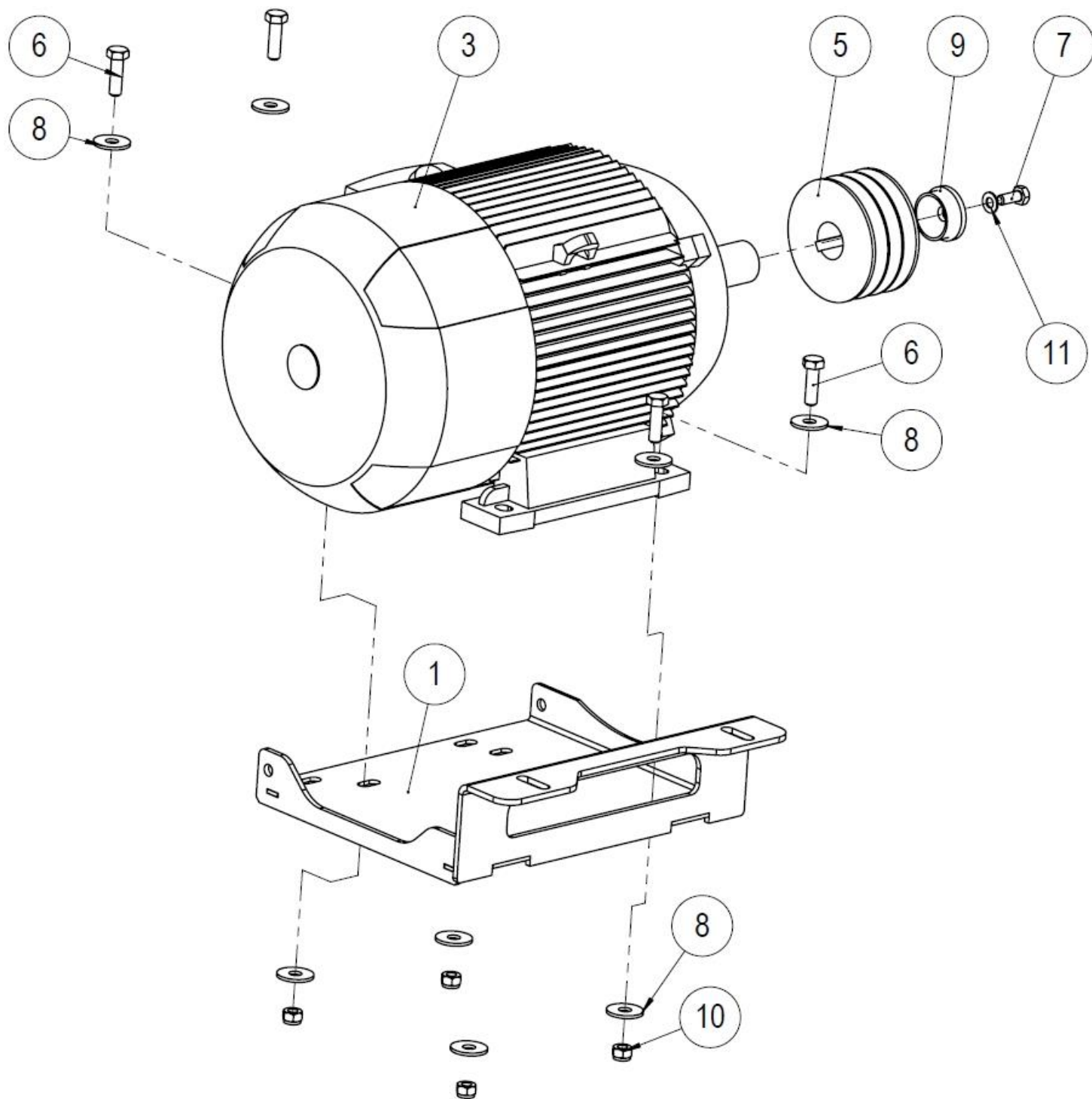

No.	Part number_Name	Pcs
1	37291_Bed for the electric motor	1
3	95041_Electric motor 10 kW	1
4	37571_Attachment plate for the motor bed	1
5	95365_Belt pulley B3,125	1
6	96148_Hex screw DIN 933 M12x40	4

7	96139_Hex screw DIN 933 M10x25	1
8	96340_Washer DIN 9021 M12	8
9	37616_Shaft end of the electric motor	1
10	96218_Lock nut DIN 985 M12	4
11	96049_Washer DIN 125 A10	1

9.4 Exploded view and parts list of the electric motor (electric model)

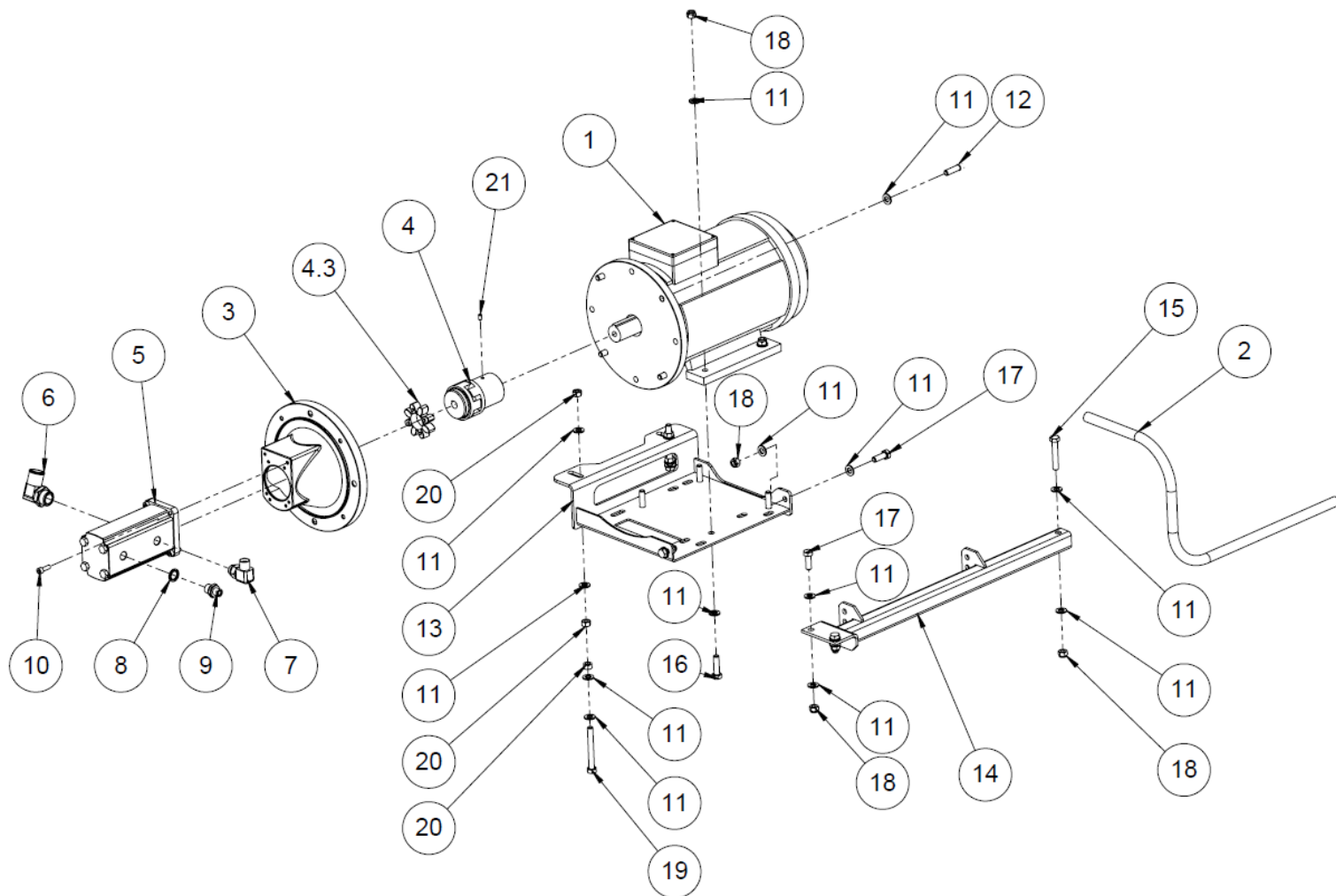

No.	Part number	Name	Pcs
1	95846	Electric motor 10 kW B35	1
2	95164	Electric cable	1
3	97350	Motor flange	1
4	97351	Intermediate switch	1
4.3	95113	Clutch rubber	1
5	97869	Hydraulic pump 32/11 ccm	1
6	97849	Suction connector 1"/32mm	1
7	97247	Directional corner nipple 1/2"	1
8	97213	USIT 1/2"	1
9	97203	Double nipple, straight 3/8"-1/2"	1
10	96035	Hex screw DIN 912 M8x25	4

11	96058	Washer DIN 125 A12	30
12	96148	Hex screw DIN 933 M12x40	4
13	37291	Electric motor bed	1
14	37514	Electric motor fastener	1
15	96110	Hex screw DIN 931 M12x70	1
16	96107	Hex screw DIN 933 M12x45	4
17	96147	Hex screw DIN 933 M12x35	4
18	96218	Locking nut DIN 985 M12	9
19	96141	Hex screw DIN 933 M12x100	2
20	96200	Hex nut DIN 934 M12	6
21	96227	Socket set screw DIN 916 M8x12	1

4.1 Exploded view and parts list of the splitting cylinder (37510)

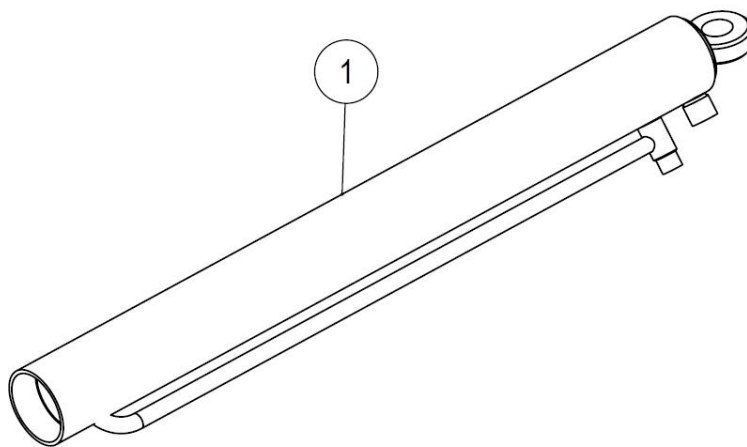
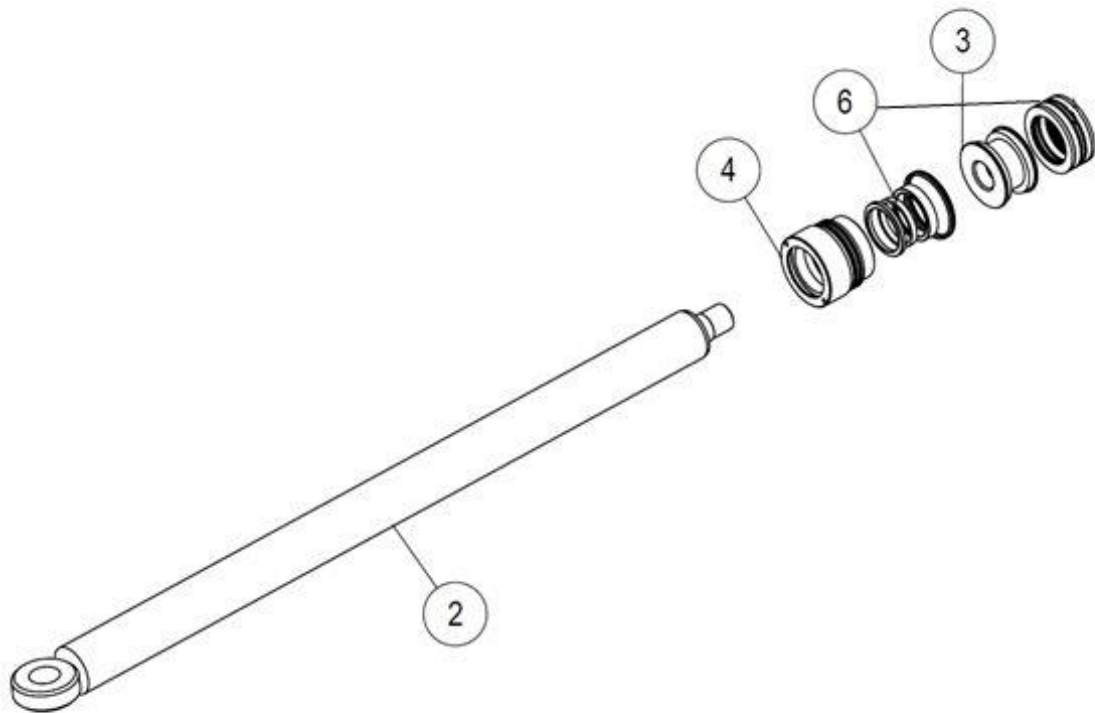

No.	Part number_Name	Pcs
1	37051_Cylinder pipe	1
2	37511_Cylinder rod	1
3	37058_Piston	1
4	60597_Rod control Ø80, 70/50	1
6	97368_Seal kit 70/50	1

4.2 Exploded view and parts list of the splitting blade cylinder (60915)

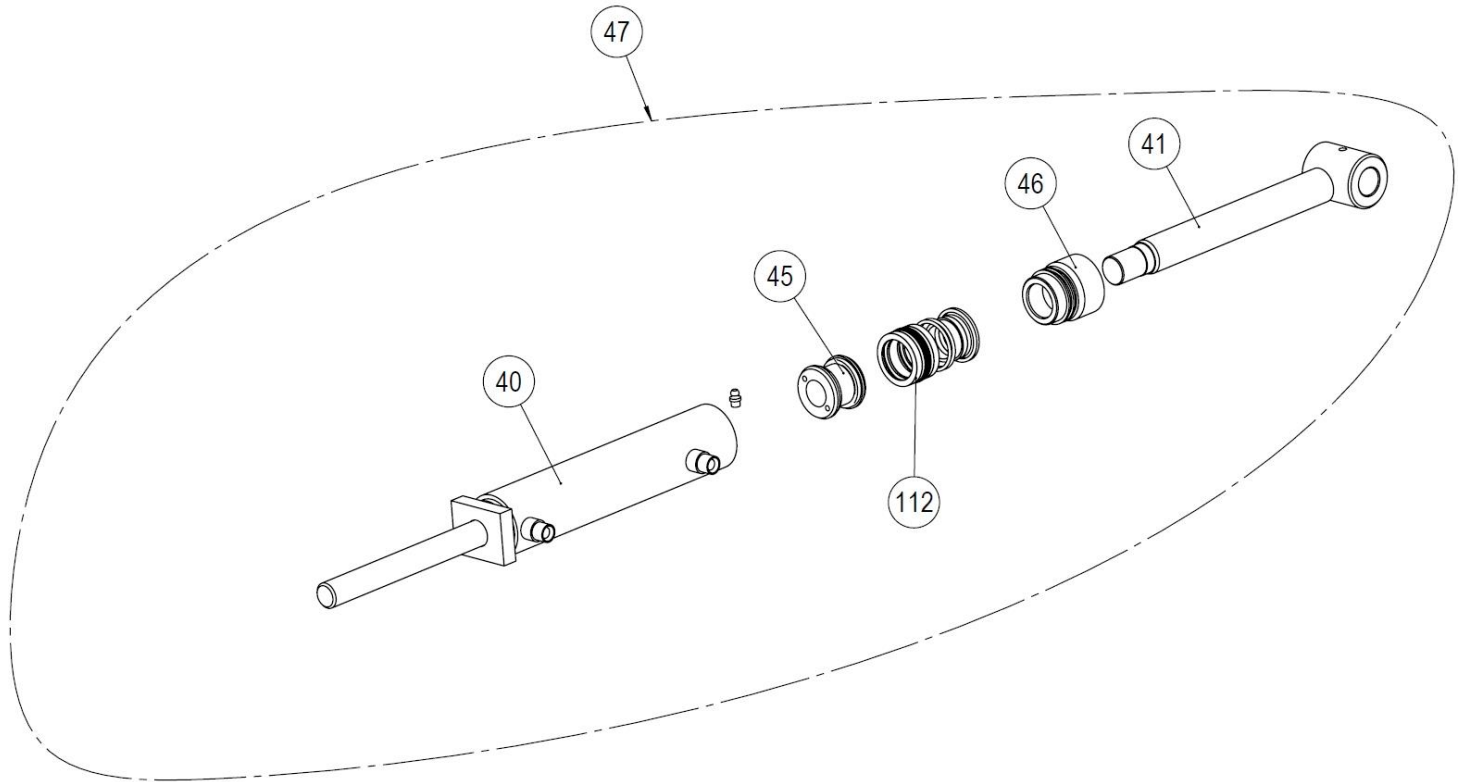

No.	Part number_Name	Pcs
40	60916_Cylinder pipe	1
41	60920_Cylinder rod	1
46	10261_Rod control	1
112	97294_Seal kit 50/32	1
45	10260_Piston	1
47	60915_Cylinder, complete	1

5.1 Figures and part numbers of the splitting blades

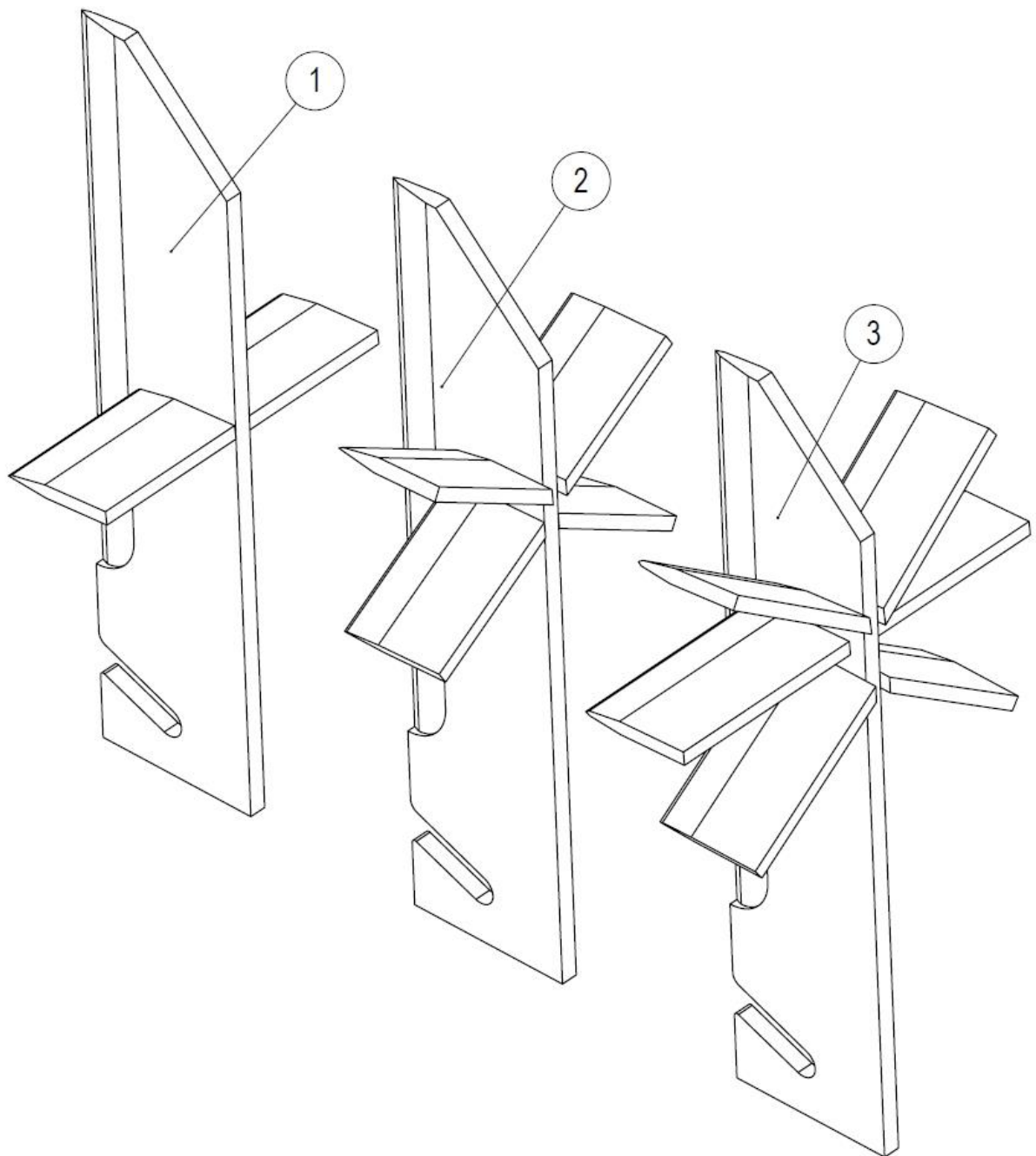

No.	Part number_Name	Pcs
1	37166_4-way blade	1
2	37671_6-way blade	1
3	37672_8-way blade	1