

USER MANUAL

Ref. No. 0458-395-0045

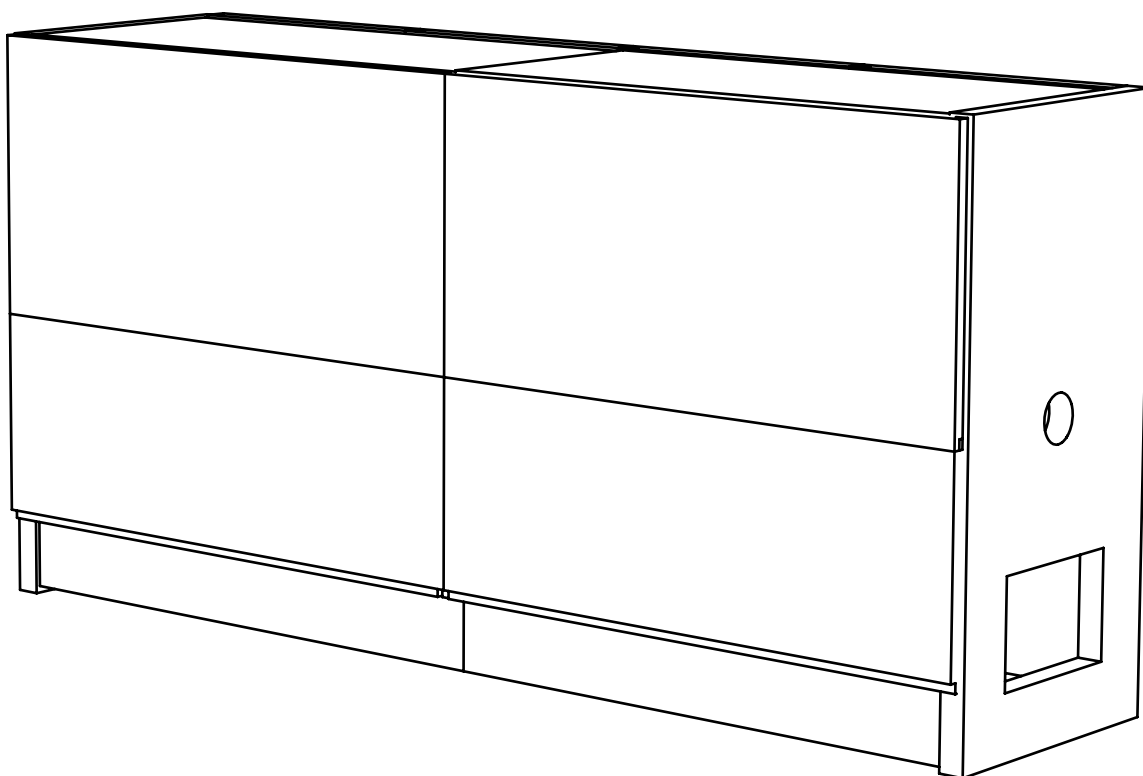

SAUNO WOOD DRYING KILN

DRYING CABINET AND
DRYING UNITS VT3 & VT5

THANK YOU FOR CHOOSING A LOGOSOL MACHINE!

Welcome! We are very pleased that you have demonstrated your confidence in us by purchasing this wood drying kiln, and we will do our utmost to meet your expectations.

Logosol has been manufacturing sawmills since 1989. In that time we have supplied approximately 50,000 machines to satisfied customers the world over.

We care about your safety as well as we want you to achieve the best possible results with your wood drying kiln. We therefore recommend that you take the time to carefully read this user manual from cover to cover in peace and quiet before you begin using the equipment. Remember that the machine itself is just part of the value of the product. Much of the value is also to be found in the expertise we pass on to you in the user manuals. It would be a pity if that were not utilised.

We hope you get a lot of satisfaction from the use of your new equipment.



Bengt-Olov Byström
Founder and Chairman,
Logosol in Härnösand, Sweden



Read through the user manual carefully and make sure you understand its contents before you use the equipment.



This user manual contains important safety instructions.



WARNING! Incorrect use can result in serious or fatal injuries to the operator or others.



LOGOSOL continuously develops its products.
For this reason, we must reserve the right to modify
the configuration and design of our products.
Document: LOGOSOL Sauno Wood Dryin Kiln User Manual
Ref. No. User Manual, English: 0458-395-0045
Text: Martin Söderberg
Illustrations: Martin Söderberg
Last revised: June 2018
© 2018 LOGOSOL, Härnösand Sweden

TABLE OF CONTENTS

Safety instructions	4
Components: drying unit	6
Components: drying cabinet	8
Tools required	10
Assembly: drying cabinet	11
Sauno drying programme	19
Wiring diagram	20
CE Declaration of conformity	21

SAFETY INSTRUCTIONS



For your own safety, do not start the drying unit without first having read and understood all the contents of this user manual. Do not let persons who have not read the instructions use the wood drying kiln.



If used incorrectly, the wood drying kiln can cause fire and serious injury.



Do not connect the power until you have installed the drying unit according to these instructions.

KEY TO SYMBOLS



This symbol means 'WARNING'. Pay particular attention where this symbol appears in the manual text.



This symbol is followed by instructions that must be observed. Pay particular attention where this symbol appears in the manual text.

GENERAL INFORMATION

The drying unit may only be used for drying wood in a chamber intended for this purpose.



In this user manual **"disconnect the power cord"** means that the cable that supplies power to the drying unit should be disconnected from the mains and placed such that no unqualified person can reconnect it. Wait until the drying unit has completely cooled.

Disconnect the power cord:

- before touching the part of the drying unit that is on the inside of the drying cabinet.
- before opening any of the inspection hatches on the drying unit.
- before cleaning or other maintenance
- before moving the drying unit.



Risk of burn injury.



The drying unit has hot heating elements. It must not be started until it is correctly installed in a drying cabinet, and the drying cabinet is closed. Never put your hands inside the drying unit if the power cord is not disconnected.

SETTING UP



Risk of serious injury.



Risk that the timber stack tip over someone.



Risk of fire if the drying unit or the timber stack tip over.



Follow the instructions below:

- Place the drying cabinet on a flat and stable surface that can stand the load of the timber.
- The timber should be stacked such that the stack becomes stable. Remember that there can be movements in the timber stack when the wood dries.
- The wood drying kiln should be placed at a safe distance from buildings and other objects that can be damaged if a fire should start. The safety distance between the wood drying kiln and flammable materials should be at least 5 m. We recommend that you contact your local fire authority for advice if you are unsure.
- For maximum electrical safety and fire safety, a residual current circuit breaker should be used.
- Ensure that the air in the drying cabinet can circulate and that the wood is not closer to the drying unit than 5 cm.
- Place the wood drying kiln such that the start / stop button is not blocked.
- Never step on the power cable of the drying unit. The cable should be protected against accidental damage.

BEFORE CONNECTING THE EQUIPMENT TO THE MAINS

- Check that the fan impeller can rotate freely, and that no loose objects are left inside the drying unit.
- Check that all inspection hatches are correctly fitted.
- Check that the power cable is in good condition.
- Check all visible fasteners. They may have to be tightened after transport.
- Check that the labelling of the drying unit matches your electrical connection.
- Check the function of the thermostat.

ELECTRICAL SYSTEMET



Risk of electric shock.



The electrical equipment may only be opened by a qualified electrician. Always disconnect the power cord before opening the electrical equipment or carrying out service on it.



Risk that condensed water accumulates in the junction box of the drying unit when there are large fluctuations in temperature and extreme weather.



Disconnect the power cord and let a qualified electrician check that the junction box is dry.

MAINTENANCE

After every fifth drying cycle or as needed:

- Disconnect the power cord.
- Remove the drying unit from the drying cabinet.
- Open the protective covers and clean the elements, the cold air intake and fan impeller of the electric motor with a soft brush, soap and water. Make sure that all water has dried before you refit the protective covers and connect the power cord of the drying unit.
- Only use original spareparts, attachments or accessories that are supplied by Logosol or that are specifically approved by Logosol for the purpose.
After service, the drying unit has to be restored to its original design. All inspection hatches and covers have to be correctly installed before the drying unit is taken into use. The equipment must not be modified or altered.
- The warning labels are there for the safety of you and others. Damaged or illegible labels should be replaced.

COMPONENTS: DRYING UNIT VT 3

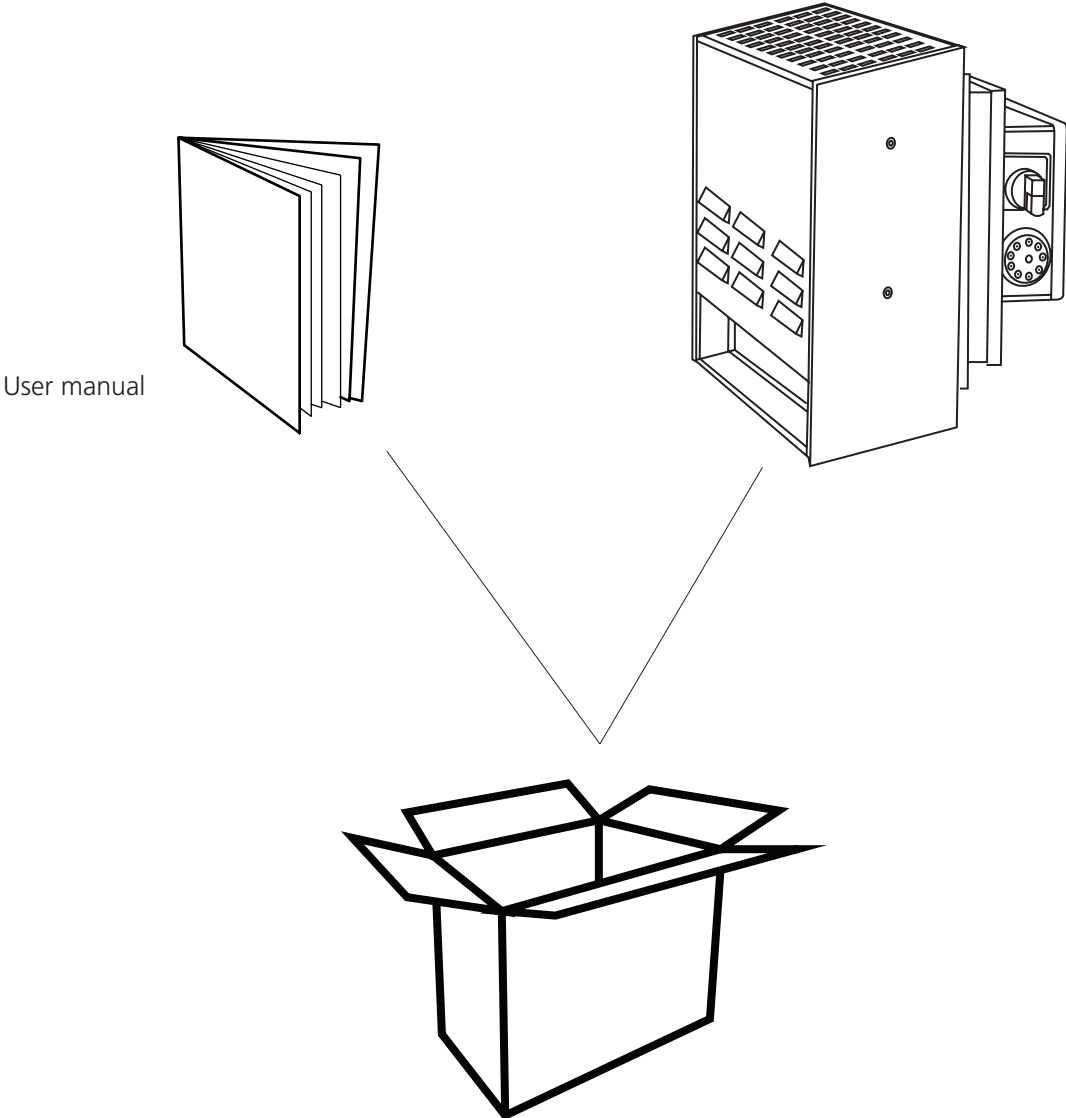

COMPONENTS: DRYING UNIT VT 5

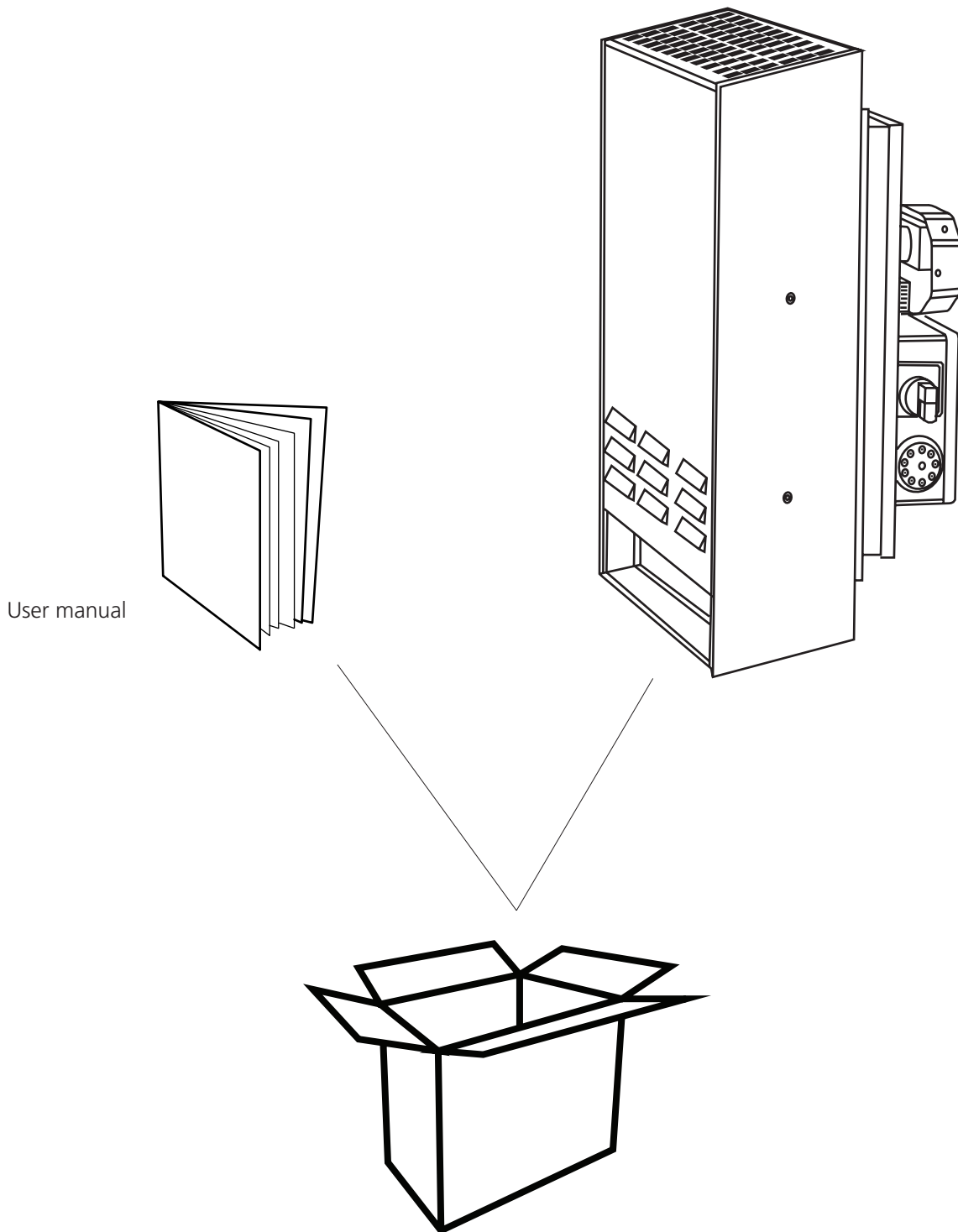

COMPONENTS: DRYING CABINET

The product comes unassembled. The shipment consists of these components. Check that all the components of the product is included in the shipment when receiving it.

User manual

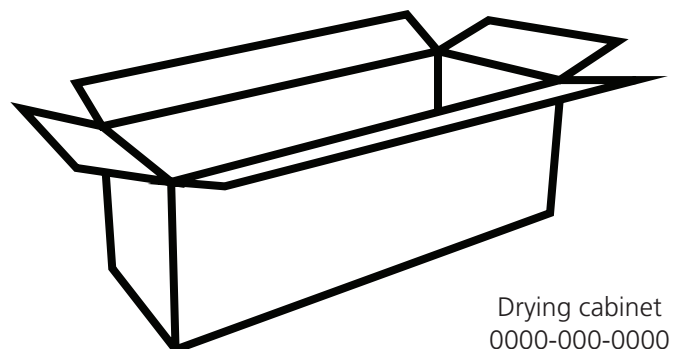
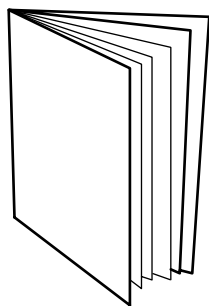

Drying cabinet
0000-000-0000

COMPONENTS: DRYING CABINET

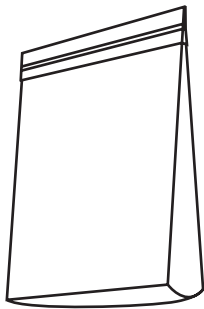
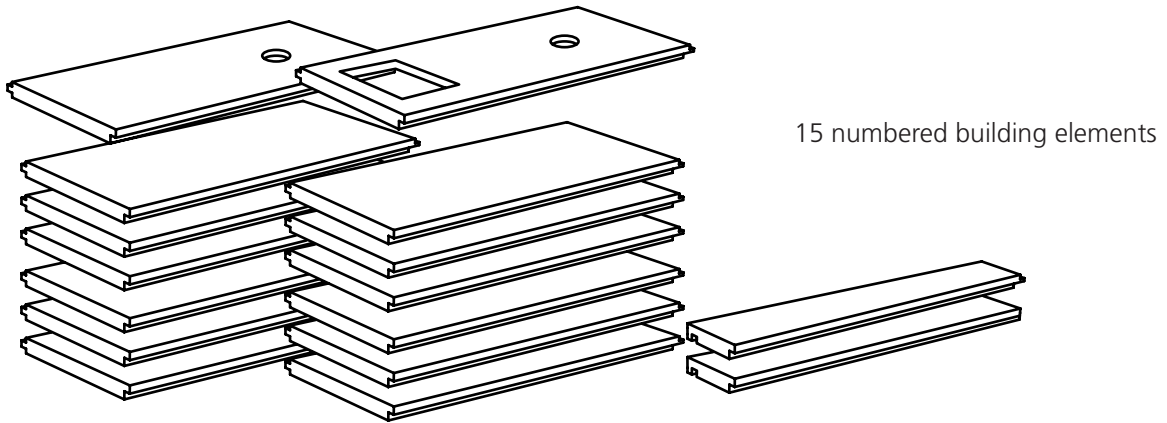

Bag
4520-001-2070

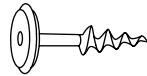

40 pc — Special screw

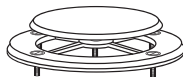

2 pcs — Air ventilator
0000-000-0000

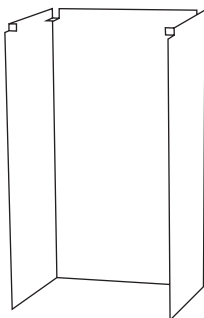

Cover

TOOLS REQUIRED



1000 ml Polyurethane glue

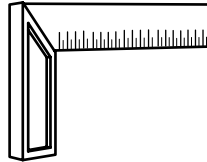

Set square



Allen key 6 mm



∅ 8 mm Drill bit

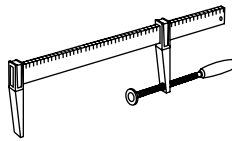

Glue clamp

ASSEMBLY SYMBOLS

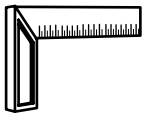

Make right-angled



Screw



Glue



Drill

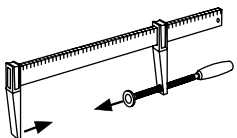

Clamp

ASSEMBLY: DRYING CABINET

The drying cabinet comes unassembled, in numbered building elements. These have to be assembled and glued as described in the instructions. We recommend that you first assemble the boards without using glue to see how the different assembly steps work. The boards have to be clamped during the assembly. It is easier if you carry out the assembly on a flat and covered surface. It is also important that you are careful when gluing, as you want the drying cabinet to be watertight.

1

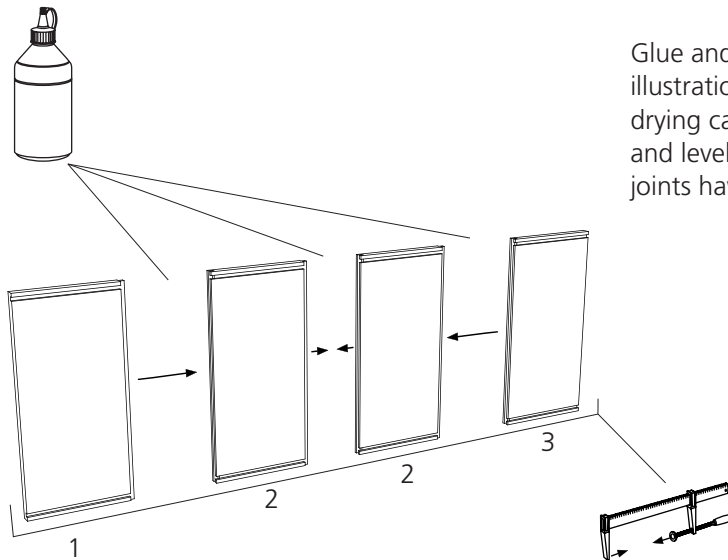

Glue and fit together the parts shown in the illustration. These boards will form the back of the drying cabinet. Make sure that the boards are straight and level with each other after gluing. The glued joints have to be clamped.

2

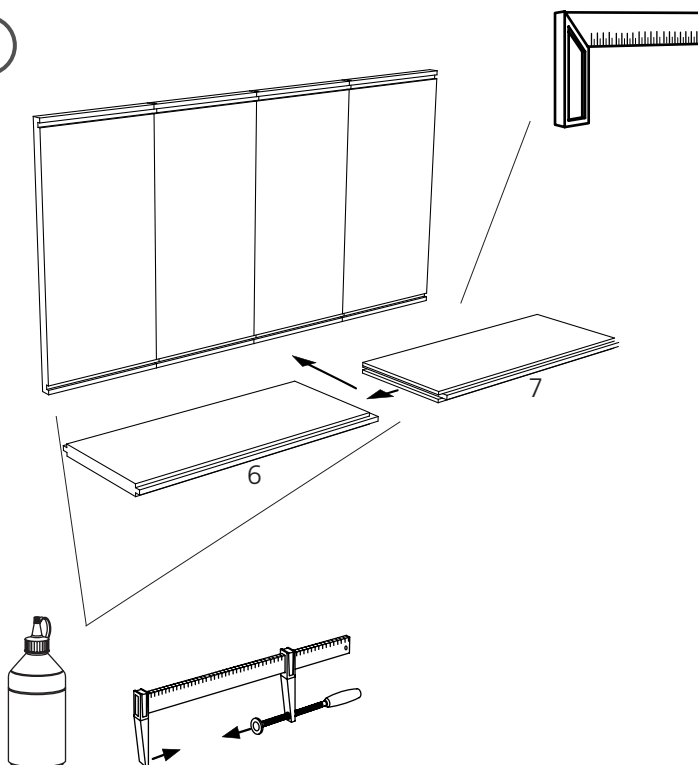

Glue and fit together the bottom boards 6 and 7 as in the illustration. The glued joints have to be clamped. Make sure that the bottom forms a right angle with the back part.

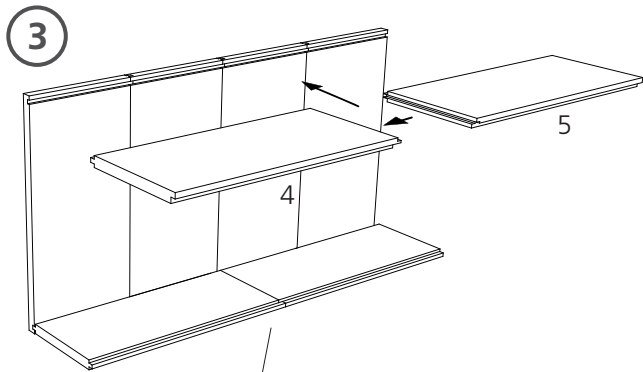

Glue and fit together the top boards 4 and 5 as in the illustration. The glued joints have to be clamped. Make sure that the top forms a right angle with the back part.

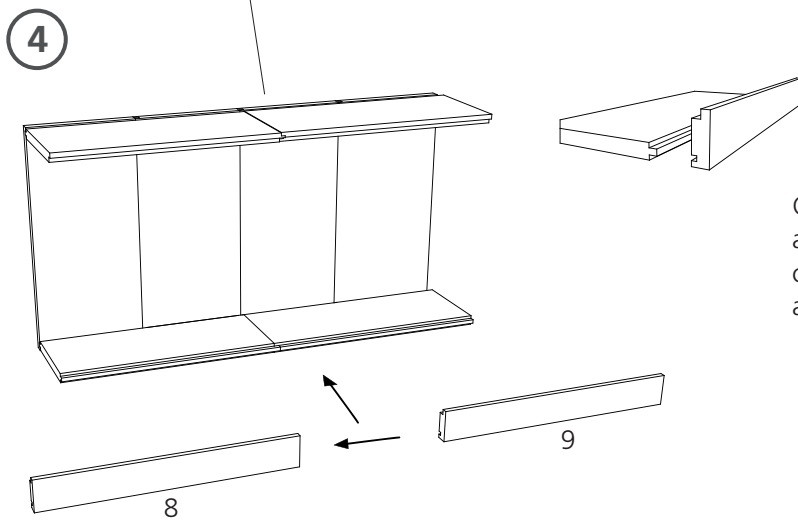
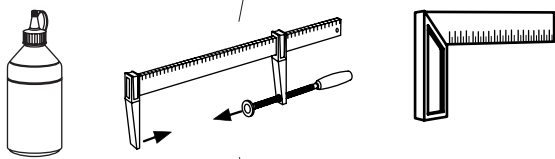

Glue and fit together the toe kick boards 8 and 9 as in the illustration. The glued joints have to be clamped. Make sure that the toe kick boards form a right angle with the cabinet bottom.

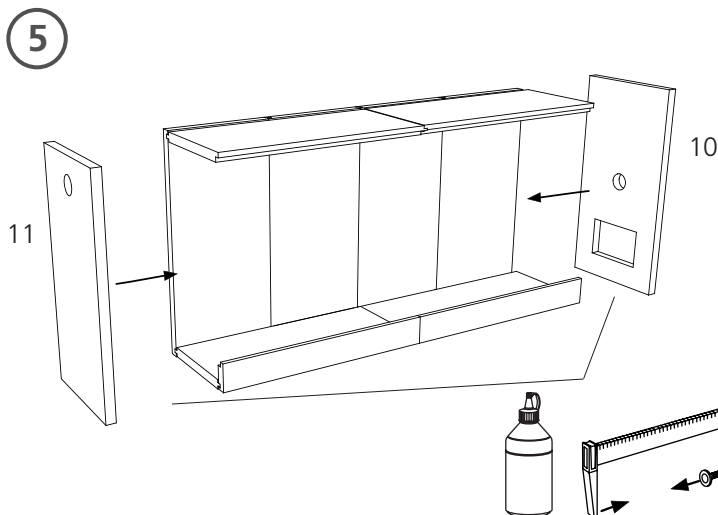

Glue and fit the side boards 10 and 11 as in the illustration. The glued joints have to be clamped.

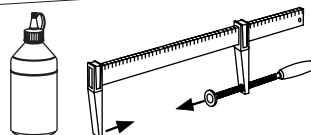

6

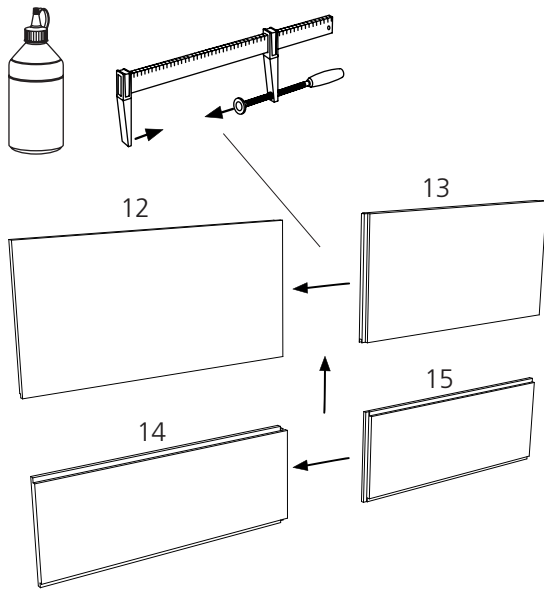

Glue and fit together the boards 12-15 to make the cabinet front/door as in the illustration. The glued joints have to be clamped. Make sure that the boards are straight and level with each other after gluing.

7

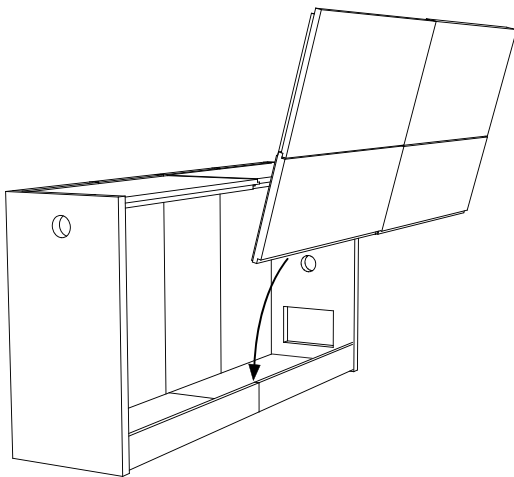

The cabinet front/door is to be fitted as shown in the illustration.

8

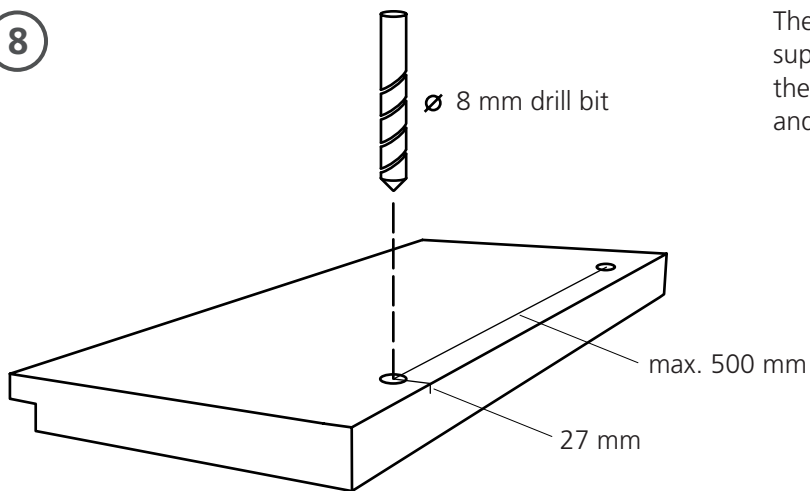

The cabinet is to be screwed together with the supplied special screws. This should be done as in the illustration: Mark the positions of the screws and pre-drill using an 8 mm drill bit.

9

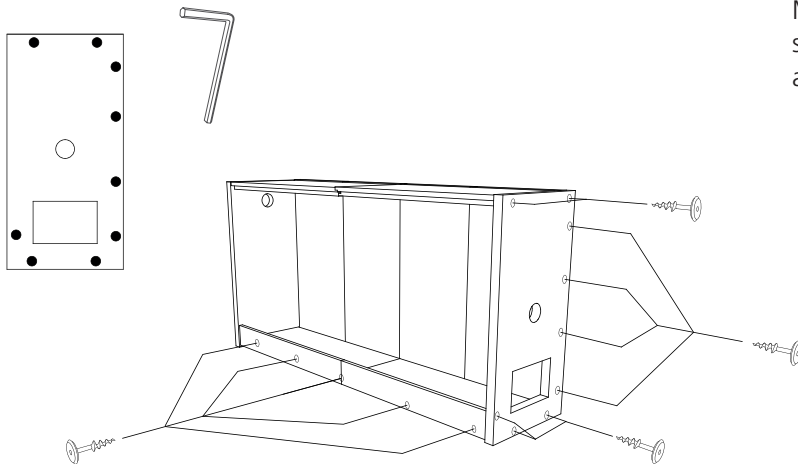

Mark the positions of the screws, pre-drill and screw in the special screws on one of the sides and on the toe kick boards.

10

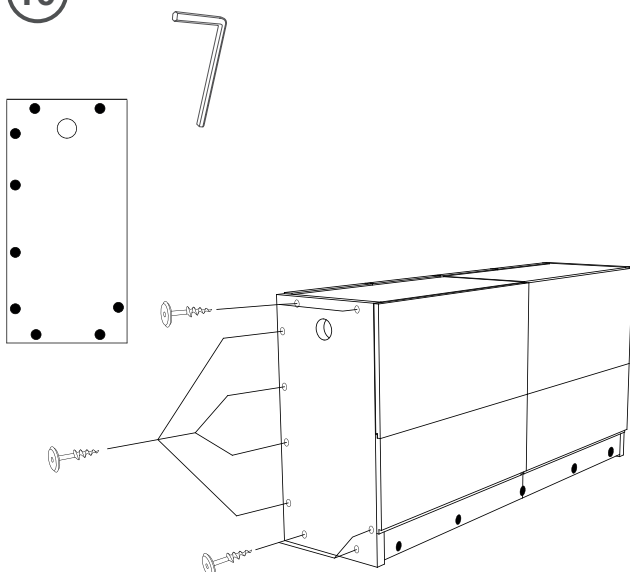

Mark the positions of the screws, pre-drill and screw in the special screws on the other cabinet side.

11

Mark the positions of the screws, pre-drill and screw in the special screws on the cabinet back.

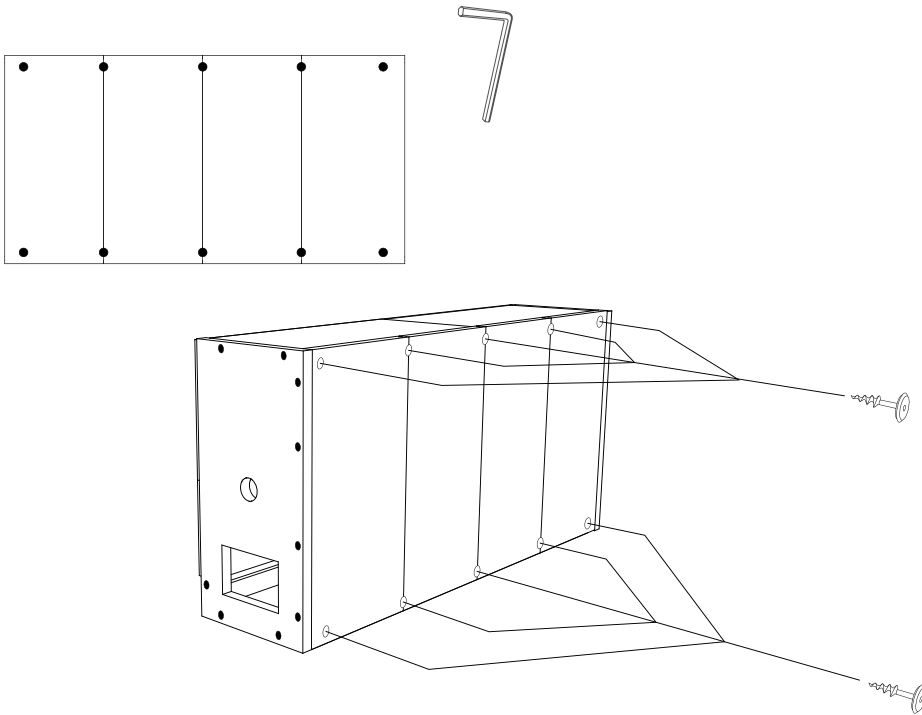

12

Install the air ventilators in the pre-cut holes.

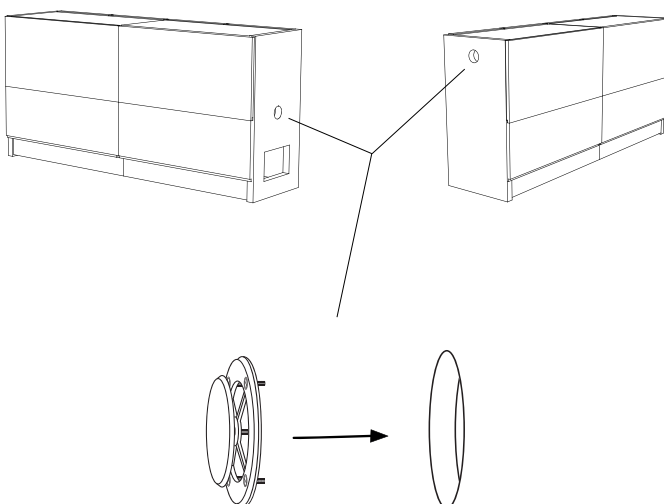

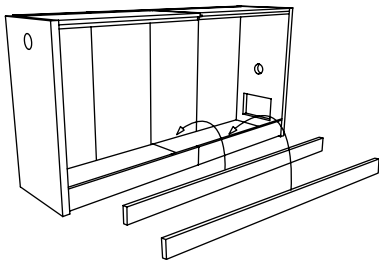

TIMBER STACK BED

The timber stack bed in the cabinet is preferably made of two 2-by-5 inch boards. Cut them to the same length as the inner length of the drying cabinet and place them as in the illustration.

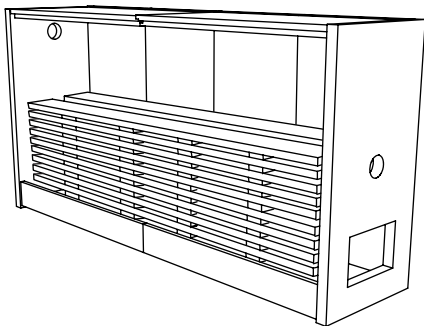
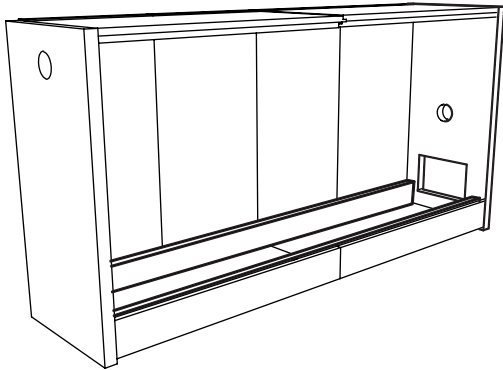

STACKING THE TIMBER

The timber should be stacked such that the drying unit is able to blow the circulating air under the timber stack. Place the timber on the bed using spacers between the layers of timber. The spacers should be at least 5 mm thick and placed at the same positions between the timber layers.

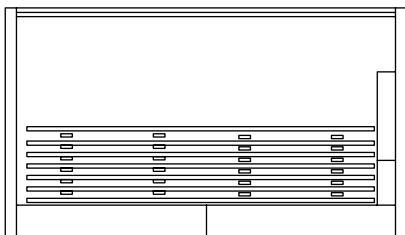

DRYING UNIT COVER

The purpose of the cover is to increase the circulation inside the kiln. The cover is fitted over the drying unit as in the illustration.

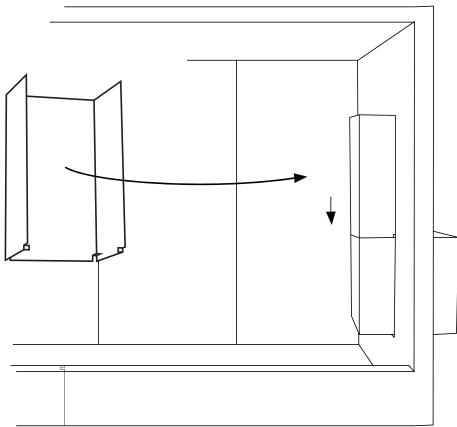

THERMOMETER

To keep track of the temperature inside the kiln, you can use a digital oven thermometer that you push through the cabinet side as in the illustration. Fit the cabinet cover on the kiln before installing the thermometer.

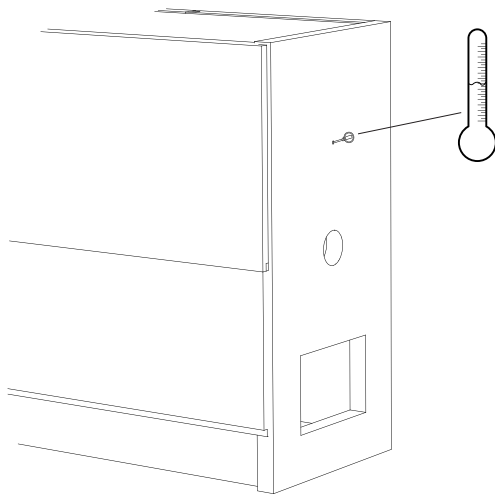

WATER DRAINS

The wood drying kiln needs two water drains to work properly. The lower drain is for draining condensed water, and the other one is for preventing the kiln from overflowing with water when steaming wood. The lower drain should be placed as low as possible in the cabinet side, and the other 90 mm above.

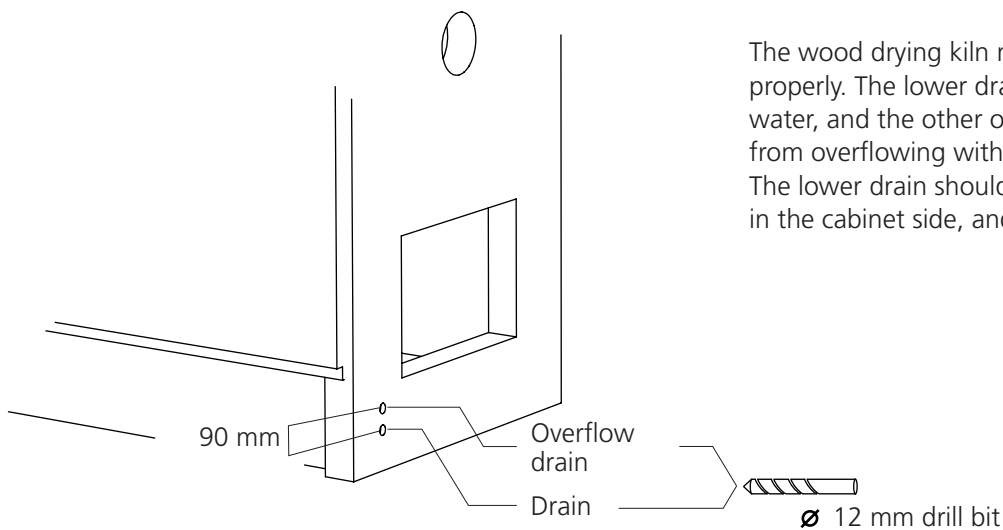

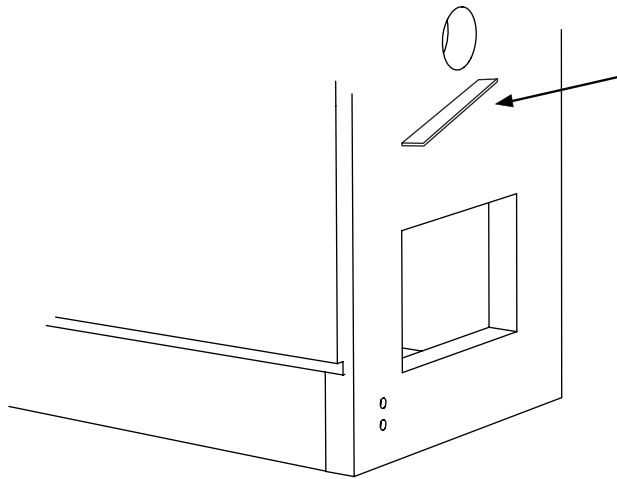

DRIP CATCHER



Under certain circumstances, condensation can accumulate at the air ventilator over the drying unit. If this is the case, it can be a good idea to fit a plate strip below the ventilator to lead away the condensed water. This way the water is prevented from ending up inside the drying unit.

SITING

The wood drying kiln can be placed both outdoors and in a room that is protected from water damage. The drying unit, however, should be protected from water, rainfall and other precipitation. Usually, the wood dries faster if the kiln is placed indoors, but remember that damp, warm wood that is drying can have a strong smell. During steaming, moisture can come out of the kiln. Use tubes to connect the drain holes to a water drainage outlet. Position the wood drying kiln such that it inclines slightly (2%) towards the water drainage outlet.

COLOUR CHANGE IN WOOD

At increased temperatures slight colour changes in the wood occurs. Timber with a large amount of sapwood and timber with a lot of knots (especially dry knots) darkens easily. But there are also benefits with high temperatures, especially when it comes to furniture timber. High temperatures force out resin from the wood, which reduces the risk of later resin bleeding. The colour changes that occur in a Sauno wood drying kiln are usually small. If you are unsure of what colour changes there will be, it can be a good idea that you first dry a smaller amount of wood as a test. For hardwood, colour changes that come when using a wood drying kiln are usually desirable. Today, most of the modern drying plants use temperatures between 70° and 110°C. The Sauno kiln uses a temperature that is max. 75°C.

SAUNO DRYING PROGRAMME

PREPARATIONS

Close the lower drain hole so that water stays inside the wood drying kiln. If the timber is newly felled, you usually do not need to pour any water into the kiln. However, it is never a disadvantage to pour 5-15 litres of water into the kiln. Oak and chestnut wood contain a lot of acid. To avoid corrosion on the drying unit, these sorts of wood should be left for at least a year before you dry them.

STEAMING

Close the drying cabinet and the air ventilators. Set the thermostat knob to 50°C and the power mode to 2. Let it run for 24 hours. The temperature in the kiln should now have reached about 50-60°C. Change the power mode to 1 and raise the thermostat a couple of degrees at a time until the temperature in the kiln has reached just over 70°C. **If the thermostat is set too high, it can cause the overheating protection to be activated.** Let the steaming process continue for about 4 days. Large-dimension timber, 3 inches and above, may need 5-8 days. During the steaming, it should never get dry inside the kiln, since this can cause the wood to crack. Refill with water if necessary. Regularly check your wood drying kiln until you have learnt how it works.

DRYING

Empty the kiln of water. Softwood: Set the thermostat to 40°C. Then slowly raise it to a suitable temperature (50°C for softwood). Hardwood: Set the thermostat to 30°C. Then slowly raise it to a suitable temperature (40°C for hardwood). (The harder the wood, the more time is needed to dry it.) Open both the air ventilators about 5-8 mm. Check at least once a day that it feels damp around the edge of the outlet air ventilator. If not, close the ventilator slightly more. If it is damp around the ventilator, you know that the humidity inside the kiln is sufficiently high for making the water in the wood travel from the inside to the outside. It usually takes 2-3 weeks before the wood is dry. With a moisture meter you can check if the wood has come down to a moisture content of 8%. Let the wood rest indoors for 1-2 weeks before using it. This gives the wood an even moisture content. Now you have the perfect furniture timber.

WIRING DIAGRAM

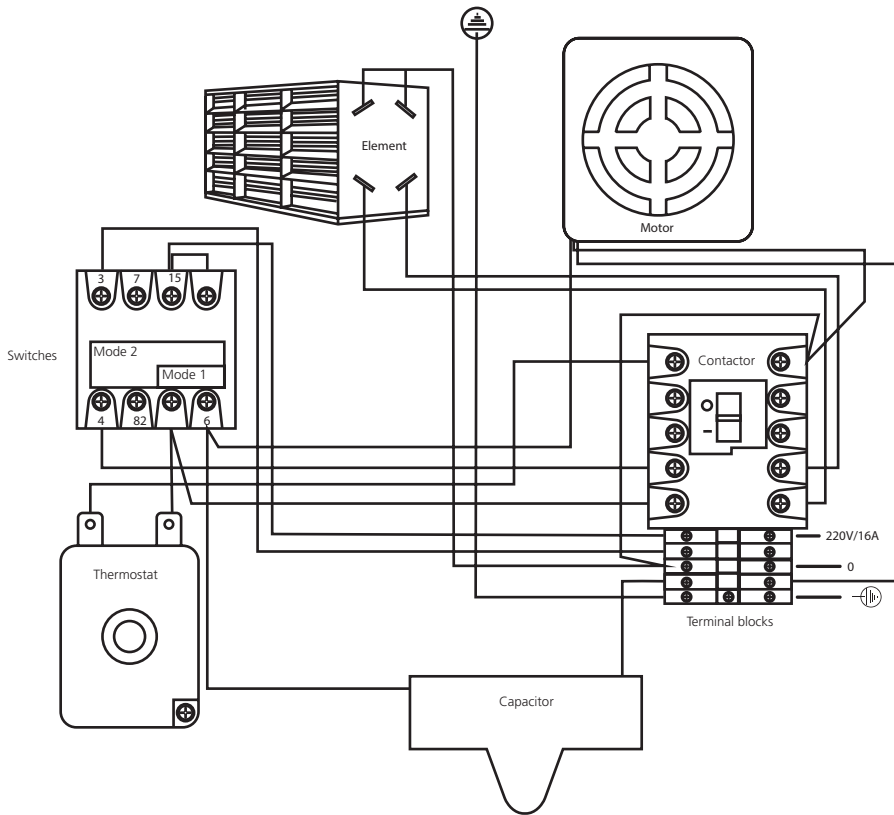

Sauno VT5

4 kW (2000 W +
2000 W) 16 A
(or 2 x 10 A)

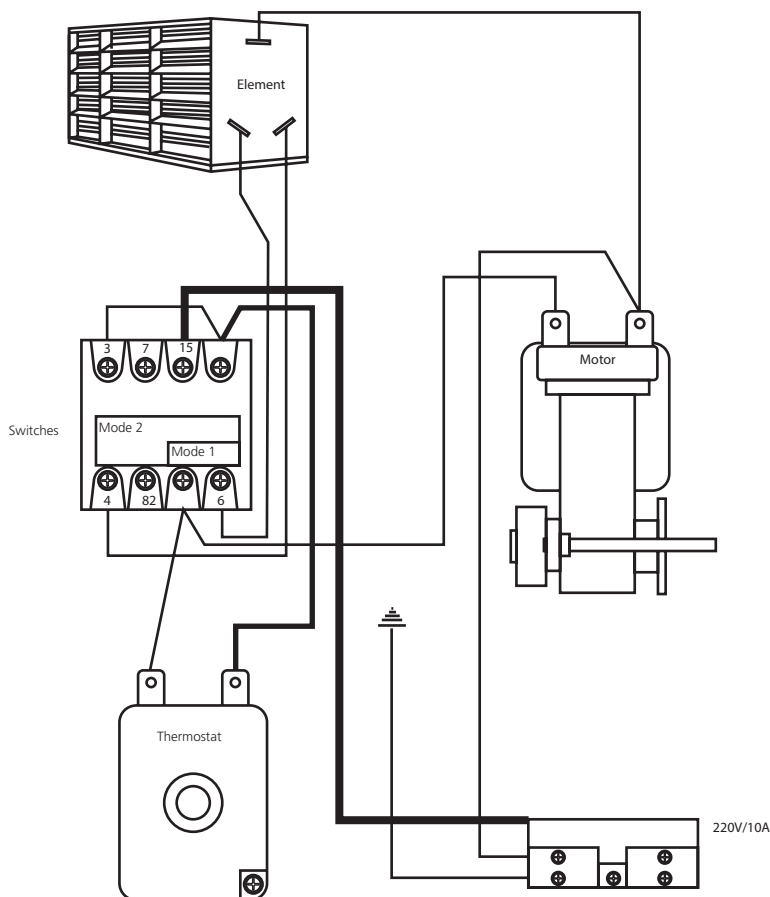

Sauno VT3

2 kW (1000 W +
1000 W) 10 A



EU declaration of conformity

LOGOSOL AB,
Fiskaregatan 2
S-871 33 Härnösand
SWEDEN
Phone +46 611 18285,

hereby declares that **Sauno Virkestork** is manufactured in conformity with:

Machinery Directive 2006/42/EG, EMC Directive 2004/108/EG and LVD Directive 2006/95/EG.

Mattias Byström, Product Manager, is responsible for technical documentation.

Härnösand 2018-09-07
Malte Frisk, CEO

NOTES

NOTES



LOGOSOL SWEDEN

Fiskaregatan 2, S-871 33 Härnösand, SWEDEN
Phone +46 611 182 85 | Fax +46 611 182 89
info@logosol.com | www.logosol.com