

HAKKIPILKE®

Easy 43



**COMBINATION OF EXPERIENCE
AND INNOVATIONS**

www.maaselankone.fi

HAKKIPIILKE®

Easy 43

The Hakki Pilke Easy 43 is an entirely new firewood processor based on the Easy 42 model, highly regarded among professional users. Despite the increased robustness of the frame, the machine is compact in terms of its dimensions and weight. The productivity of the machine has been improved with excellent delay-free splitting force as well as new features that ensure uninterrupted material flow – a hydraulic log clamp, a hydraulically retracting measuring device and log landing plates. If the machine is mainly used to process sizeable logs, user can also opt for the wider output conveyor used in the Easy 50s model.

In terms of the operator, the most significant update is the user interface that provides a fully revamped user experience. Sawing takes place with the press of a button and always automatically applies the optimal force – user doesn't need to worry about the adjustments. Combined with the automatic chain tensioner and the electric chain lubrication pump ensures that the saw chain and bar last for a long time and provide unparalleled cutting efficiency time and time again. User can set the feed assist mechanism to feed in logs during every splitting motion, ensuring that a new splitting action can always be activated optimally when the pusher's return motion begins.

The model boasts a wealth of features that reduce operating costs. The large oil capacity enables longer oil change intervals and uninterrupted operation in all conditions from Alaska to Australia. Reliable electric control minimises the number of elements and components that require maintenance. Adjusting the amount of the chain lubrication oil supplied is easy, so user can ensure that it is not wasted. User can also replace the oil canister, eliminating the need to pour oil from one container to another. The power transmission features no V-belts, which ensures consistent reliability and performance year after year.





The hydraulic log press enables logs of all sizes to be sawed effortlessly.



The machine's functions can be easily controlled with the ergonomic and easy-to-use control panel.



EASY 43

-  430 mm
-  600 mm
-  15 t



A cleaning out-feed conveyor which features hydraulic lateral adjustment is provided as standard. A wider cleaning out-feed conveyor with full hydraulic adjustment (below) is available as an accessory.



- NEW POWERFUL ONE BUTTON-OPERATED SAW
- POWER WITHOUT COMPROMISING SPEED
- VERY FEW WEAR PARTS
- AUTOMATIC HYDRAULIC CHAIN TENSIONER AS STANDARD



The electrical chain oil pump adjustment is easy to operate with the adjustment screw in the figure.



The guide plates ensure that even the shortest pieces of wood fall neatly into the splitting groove.



TECHNICAL SPECIFICATIONS

Max log diameter	430 mm (16.9 in)
Max log length	600 mm (23.6 in)
Maximum splitting power	15 t
Bar	18"
Power source	PTO, sähkö, combi
Splitting blade	2/4 os.
Out-feed conveyor measures	4 m x 250 mm (157.5 in x 9.84 in)
In-feed conveyor length	2,5 m (98.4 in) *

Standard equipment

AC10 automatic chain tensioner (hydraulic)
Hydraulic swivel out-feed conveyor
Cleaning out-feed conveyor
Automatic speed valve, 3 speeds
Safety cover
Automatic chain oil lubrication
Automatically optimised saw press mechanism
Button-operated saw
Hydraulically retracted log measuring device
Log feed assist mechanism
In-feed guide plate
Roller hose kit
Accessory valve
Hydraulic log press
Guide plates for falling wood pieces
Out-feed conveyor speed control
Toolbox

DIMENSIONS in transport position**

Height	2560 mm (100.7 in)
Width	2540 mm (100 in)
Depth	1500 mm (59.1 in)
Weight	1400 kg (3086 lbs)

Optional equipment

Oil heater	
Hydraulic vertically and laterally swivelling large out-feed conveyor	4 m x 400 mm (157.5 in x 15.7 in)
Out-feed extension	1 m (3.28 ft) ***
Blower sawdust removal	
Oil cooler	
Splitting blade	6, 8, 12 os.

Accessories

HakkiFeed	422, 471, 472, 473
HakkiLift	421
Cleaner	
Powerpack	

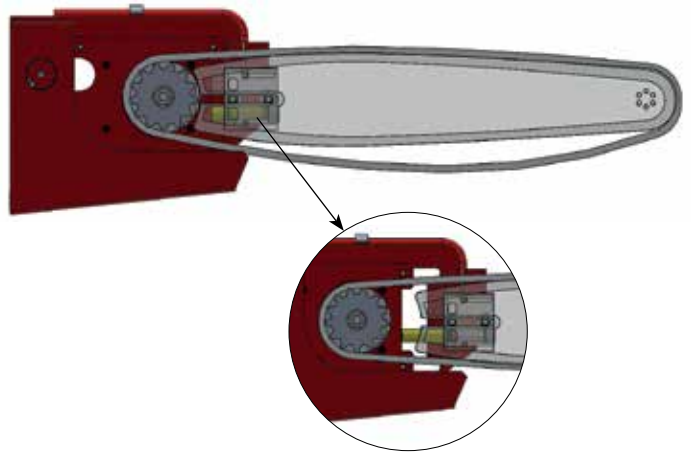

HAKKIPILKE® AC10

The patented Hakki Pilke AC 10 automatic chain tensioner keeps the firewood processor chain at an optimal tension, thus preventing the chain from disconnecting and breaking. The correct chain tension notably increases the service life of the chain and bar. The AC 10 requires no manual tensioning. The AC 10 operates hydraulically to enhance log cutting in the Easy 43 processor.

The automatic chain tensioner makes replacing the chain quick and easy. You can replace the chain in under 40 seconds, which significantly increases productivity.

* length with a hydraulic in-feed roller

** combi -modell with standard out-feed conveyor

*** The machine can be placed in the transport position only with the original conveyor. Pay attention to transport when installing the output extension.

The manufacturer reserves the right to make changes.

Manufacturer

MAASELÄN KONE OY

Valimotie 1, FI-85800 Haapajärvi, FINLAND
Tel. +358 8 772 7300, Fax +358 8 772 7320
info@maaselankone.fi, www.maaselankone.fi

Retailer

Davies Implements Ltd

Blaenteg, Trevaughan, Carmarthen SA31 3QN

Tel: 01267 237726

sales@daviesimplements.co.uk
www.daviesimplements.co.uk