

FARMI® FOREST

Profitable choice - since 1962

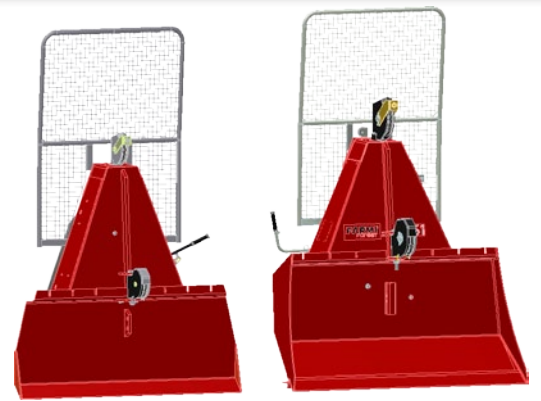

FARMI 51 AND FARMI 61 SKIDDING WINCHES

FARMI, a pioneer in winch construction, has a series of three-point mounted winches for demanding applications. The development of the FARMI models is based on 50 years of experience in winch construction. Solid construction guarantees a long working life and comfortable operation.

High drum storage capacity, uniform winding, light-weight, compact design, reliable function and close attachment are the main features of FARMI skidding winches. The FARMI winch is a safe and high-performance tool that can be used practically in most forest applications.



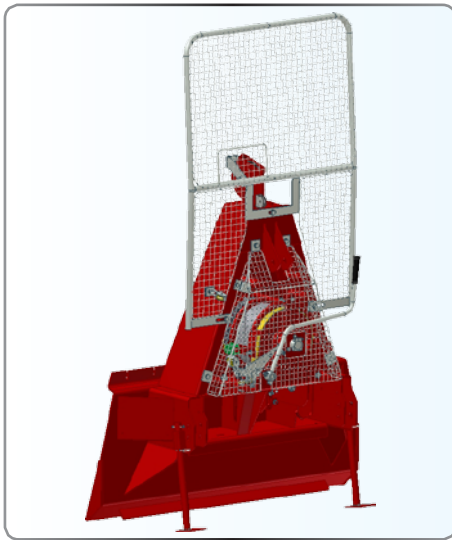

FARMI 51

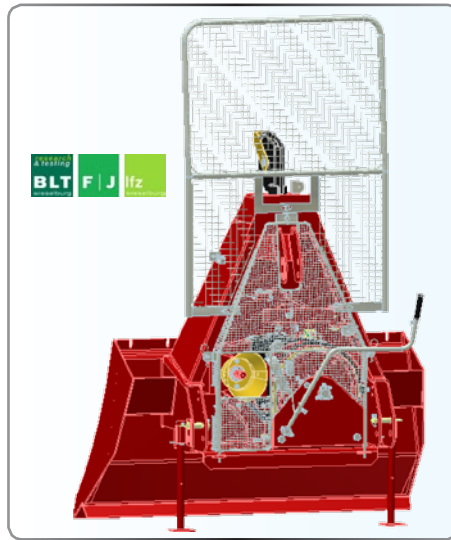

FARMI 61

FARMI winches are designed for winching and skidding of full trees and cut to length logs.

- Excellent pulling force at all wire rope lengths
- Automatic overrun drum brake – easy wire rope extraction
- Long working life time
- Long distance from upper pulley to drum - for good spooling
- Wide, robust and well shaped butt plate – stable and good to work with
- Reliable clutch for all weather conditions
- Electrohydraulic / remote control available as retrofit
- Easy to maintain
- Safe construction according to CE-regulations

TECHNICAL DATA	FARMI 51	FARMI 61
Line pull, max	50 kN	60 kN
Drum storage capacity	Ø 10 mm, 80 m Ø 11 mm, 70 m Ø 12 mm, 60 m	Ø 10 mm, 130 m Ø 12 mm, 100 m Ø 14 mm, 70 m
Line speed	350 rpm: 0,30-0,90 m/s 540 rpm: 0,50-1,40 m/s	350 rpm: 0,36-0,82 m/s 540 rpm: 0,56-1,26 m/s
Clutch	Friction Disc	Friction Disc
Required power, min.	35 kW (50 hp)	45 kW (60 hp)
Power transmission	Power take-off (tractor)	Power take-off (tractor)
Weight (without wire rope)	320 kg	503 kg
Three point linkage mount.	Cat. II	Cat. II
Dist. between upper pulley & drum	735 mm	1050 mm
PTO height	483 mm	700 mm
Chain catch / holder stow box	yes / no	yes / yes
Lower pulley / Band brake	yes / yes	yes / yes
Safety guard / auto. overrun brake	yes / yes	yes / yes
Rope guiding pulley	option	option
Butt plate, width & height	1504 x 680	1600 x 841
EHC / Remote control	option / option	option / option
Undwinding device	no	option

JL5161EN 05/2013 NHa

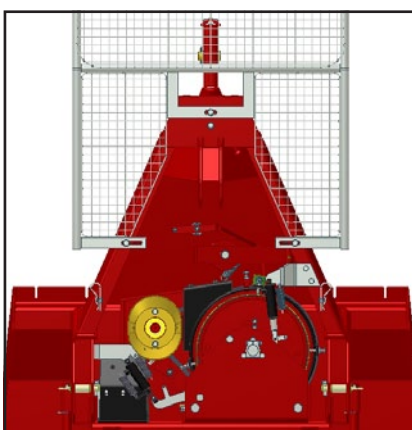

Distance and angle

between the upper pulley and the drum is very important for consistent and reliable wire rope winding.

The automatic overrun drum brake

guarantees that the wire rope can be easily extracted. In the case of abrupt stops, immediate brake action hinders drum overrun.

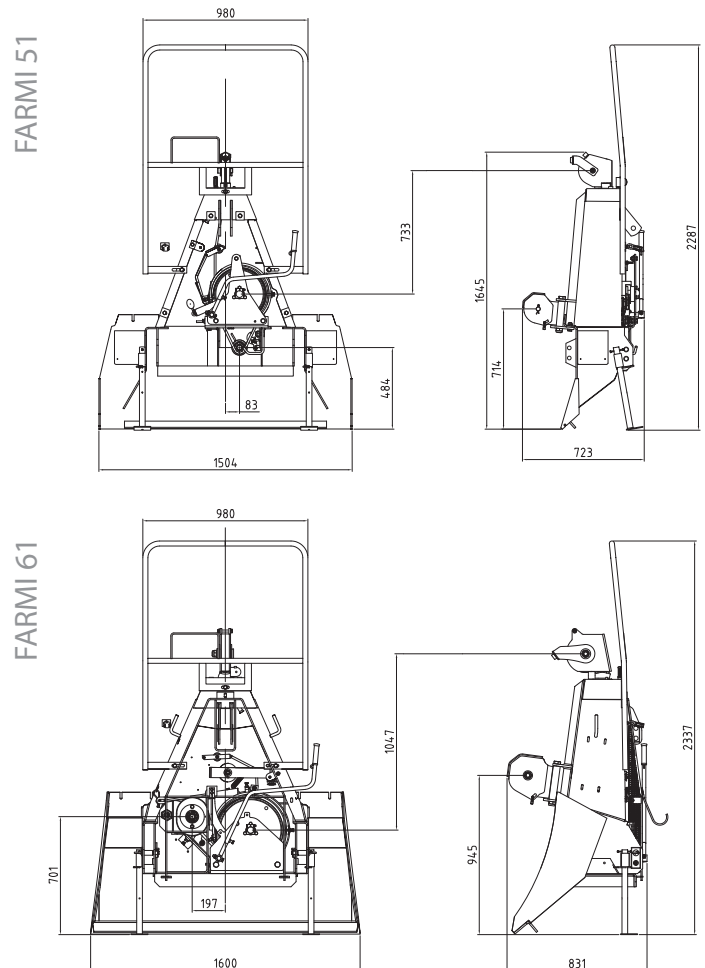

Undwinding Device

Available for models Farmi 60 – 80. Extend life span of wire rope and helps to unwind the wire rope to trees (as accessory).

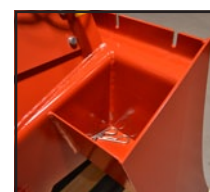

Storage box

is incorporated for carrying chokers and accessories.



HOF 4

Electrohydraulic control with manual or remote control (as accessory).